

March 2015

# CAN Newsletter

Hardware + Software + Tools + Engineering



*CAN FD and the CRC issue*

*Stand-by transceiver with fail-safe features*

*Automated validation of CAN FD networks*

*CAN FD simulation in real-time systems*

*Focus on CAN FD*

[www.can-newsletter.org](http://www.can-newsletter.org)



# CAN FD Interfaces for High-Speed USB

## ■ PCAN-USB FD

Single Channel CAN FD Interface

- Adapter for High-speed USB 2.0
- Time stamp resolution 1  $\mu$ s
- CAN bus connection via D-Sub, 9-pin
- Complies with CAN specifications 2.0 A/B and FD
- CAN FD support for ISO and Non-ISO standard switchable (with firmware update coming in Q1-2015)
- CAN FD bit rates for the data field up to **12 Mbit/s**
- CAN bit rates from 40 kbit/s up to 1 Mbit/s
- Measurement of the bus load including error and overload frames on the physical bus
- Induced error generation for incoming and outgoing messages
- Switchable CAN termination and 5-Volt supply
- Galvanic isolation up to 500 V
- Extended operating temperature range from -40 to 85 °C

Scope of Supply for all CAN FD Interfaces

- CAN FD interface drivers for Windows 8.1, 7, Vista and **Linux** (32/64 bit)
- PCAN-View: Software for monitoring CAN and CAN FD busses for Windows (32/64 bit)
- PCAN-Basic: API for developing applications with CAN and CAN FD connection for Windows (32/64 bit)

## ■ PCAN-USB Pro FD

Dual Channel CAN FD & LIN Interface

- Adapter for High-speed USB 2.0
- Time stamp resolution 1  $\mu$ s
- Transmitting and receiving of CAN FD and LIN messages using two D-Sub connections
- Complies with CAN specifications 2.0 A/B and FD
- CAN FD support for ISO and Non-ISO standard switchable (with firmware update coming in Q1-2015)
- CAN FD bit rates for the data field up to **12 Mbit/s**
- CAN bit rates from 40 kbit/s up to 1 Mbit/s
- Measurement of the bus load including error and overload frames on the physical bus
- Induced error generation for incoming and outgoing messages
- Switchable CAN termination and 5-Volt supply
- Each CAN channel is separately opto-decoupled against USB and LIN up to 500 V
- Extended operating temperature range from -40 to 85 °C

**LIN operation properties ...**

- Bit rates from 1 kbit/s up to 20 kbit/s
- Both LIN channels (common ground) are optodecoupled against USB and CAN FD
- Can be used as a LIN master or slave (1 ms master task resolution)



## Focus on CAN FD

Someone found it: the needle in the haystack. CAN FD experts have already fixed the detected CRC weakness. Fortunately, it did not have a great impact on the progress of CAN FD tool developments and applications. We take a look at the root cause for this issue as discussed during the ISO standardization process.

## Imprint

### Publisher

CAN in Automation GmbH  
Kontumazgarten 3  
DE-90429 Nuremberg

publications@can-cia.org  
www.can-cia.org  
www.can-newsletter.org

Tel.: +49-911-928819-0  
Fax: +49-911-928819-79

CEO Holger Zeltwanger  
AG Nürnberg 24338

PDF subscribers: 6000

### Editors

(pr@can-cia.org)

Annegret Emerich

Cindy Weissmueller

Holger Zeltwanger  
(responsible according  
to the press law)

### Layout

Nickel Plankermann

### Advertising manager

Gisela Scheib  
(responsible according  
to the press law)

### Distribution manager

Julia Dallhammer

### © Copyright

CAN in Automation GmbH

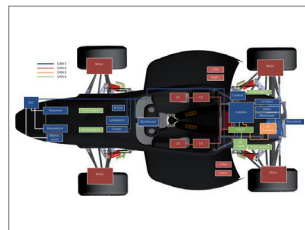

## Applications

Swift but sensitive movements	12
Four CAN networks for electrical racing car	28



## CAN FD

CAN FD and the CRC issue	4
Stand-by transceiver with fail-safe features	16
CAN FD simulation in real-time systems	30
Automated validation of CAN FD networks	32



## Engineering

Data flow transparency	34
CANopen safeguards	36
World champion in tradeshows	40



## Sensors

Sensor fusion is on the agenda	18
Digital transmission in pressure sensors	24

# CAN FD and the CRC issue

During ISO standardization the original CAN FD protocol needed to be modified, in order to maintain the high level of reliability of Classical CAN. This article illustrates the root cause for this issue as discussed during ISO standardization, shows examples, and describes the solution.

During the standardization processes of CAN FD, a CRC issue was discovered in the ISO/CD 11898-1 version from 2014-08-12. The ISO Task Force decided to solve this issue by changing the FD frame format. This solution has already been included into ISO/CD 11898-1 version from 2014-10-15.

Classical CAN has a known Cyclic Redundancy Check (CRC) weakness. More specifically, in Classical CAN a pair of bit errors in a frame generating/eliminating stuff conditions may reduce the Hamming Distance (HD) to 2. This means that a receiving node may accept a frame and give a positive acknowledge even if this frame has two bit flips. This case was first reported in a paper by Bosch for the ISO task force on CAN (1989) and first published in the SAE paper 900699 by Unruh et al. It is also explained in 1999, “Multi-Bit Error Vulnerabilities in the Controller Area Network Protocol”, a thesis paper by Eushian Tran at the Carnegie Mellon University.

In order to prevent CAN FD from inheriting the described CRC weakness, the CRC calculation in CAN FD includes the dynamic stuff bits. However, this change made the CRC calculation more vulnerable to the fault type “shortening or lengthening of the bit sequence” under specific conditions. Cases can be constructed where the receiving node accepts a frame that was falsified by just a single error. This vulnerability in the ISO/CD11898-1 version from 2014-08-12 was detected and solved. The version from 2014-10-15 contains the solution and therefore has a slightly modified FD frame format, which is also robust against shortening or lengthening of the bit sequence. To clearly outline which fault types might occur, we take a look at a fault model. The two considered fault types are fault type A and fault type B.

## Fault type A: Bit flip

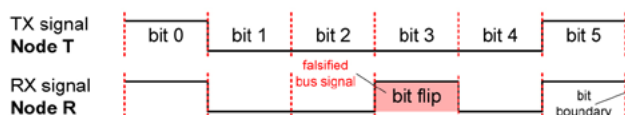

Figure 1: A receiving node samples a bit with the inverse value

## Fault type B: Shortening or lengthening of the bit sequence

A receiving node synchronizes on a glitch. Due to this synchronization, in a bit sequence the receiving node may sample one bit less or one bit more than was actually transmitted by the transmitting node. From the receiving node's

point of view this is a shortening (one bit less) or lengthening (one bit more) of the bit sequence. Fault type B can also occur in connection with stuff bits. The shortening and/or lengthening may happen several times per frame. Inside one frame either shortening or lengthening is likely to happen. Which one is more likely is determined by the relation between the transmitter's and the receiver's clock rates.

Figure 2 shows an example where the receiving node resynchronizes into the wrong direction due to a falsified bus signal. As a consequence the receiving node samples the bit sequence “100000i” as “100001”.

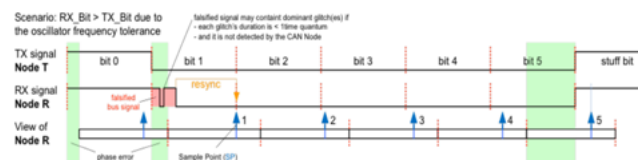

Figure 2: Example for a shortening of the bit sequence

Figure 3 shows an example where the receiving node resynchronizes into the wrong direction due to a falsified bus signal. As a consequence the receiving node samples the bit sequence “100001” as “100000i”.

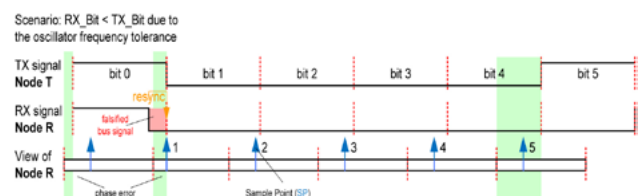

Figure 3: Example for a lengthening of the bit sequence

## Root cause for the CRC issue

The receiving node compares the calculated and received CRC bit sequence to decide if a frame can be accepted or not, i.e. if it was received correctly or not. The CRC result is reliable if the CRC-algorithm is applied exactly to the same number of bits (frame length) on sender and receiver side. In this case, the term Hamming Distance can be used. A Hamming Distance of  $n$  expresses that frames with up to  $n-1$  falsified bits are detected by the CRC-algorithm as erroneous. The CRC algorithm may or may not detect frames with  $n$  or more falsified bits as erroneous.

If the receiving node applies the CRC-algorithm to a different number of bits (less or more) than the transmitting node, the result of the CRC-algorithm has to be regarded as corrupted. This means that a corrupted frame could lead to a positive CRC result too.

# Your Source For *SYSTEM INTEGRATION*

Murphy's PowerView displays integrate your control systems and machine data in a powerful, rugged package. With superb environmental specs, bonded screen and sealed connectors, it provides durable performance even in the harshest applications.

## PowerView™

Freely Configurable Displays

Colour and Monochrome Displays

Freely configurable HMI graphics, state machines, diagnostics, CAN messaging and scripting/activity programming

Compatible with CAN 2.0B, SAE J1939, CANopen, freeform

Sunlight Visibility, Works With Polarized Glasses

- Ultra-bright LCD, Bonded to Eliminate Fogging

Robust and reliable: suitable for use outside the cab

- Class-leading environmental protection: IP67, -40°C to +85°C

## PowerCore™

Controller, Input/Output & Power Distribution Modules

Seamlessly add CAN-controlled solid-state I/O and power distribution where you need it with the PowerCore IX3212. This Power Distribution Module directly drives high-power motors, lamps, actuators and loads via a four-wire power and CAN connection. Improve your control, reliability and load diagnostics while saving on wiring and labour costs.

Reduce wire harness cost with IX3212

Power Distribution Modules:

- 12 outputs: 15A per output/70A per module, on-off/PWM/H-bridge
- 12 digital & 8 analogue inputs

***Integrate your total package with Murphy products!***

Learn more at [www.fwmurphy.com/ciintegration](http://www.fwmurphy.com/ciintegration)

Or Call: **USA** +1 918 317 2605  
**UK** +44 1722 410055  
**China** +86 21 6237 5885

**Latin America** +1 918 317 2500  
**South Korea** +82 70 7951 4100  
**India** +91 91581 37633



PV 380



PV 450



PV 780

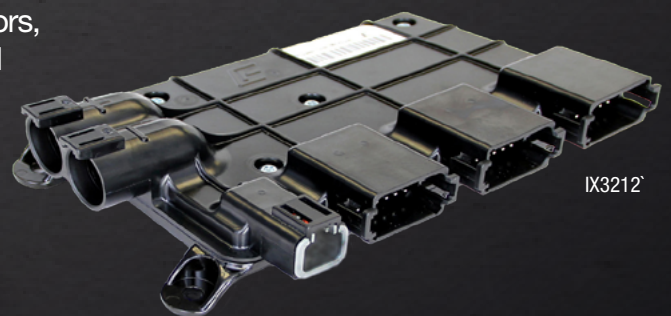

IX3212

# MURPHY®

by **ENOVATION** CONTROLS

The consequences for the fault types are:

- ◆ Fault type A: The frame CRC is a valid method to detect bit flips. The provided Hamming Distance depends only on the used CRC-polynomial and the length of the frame.
- ◆ Fault type B: Due to the shortening and lengthening of the frame, the CRC is corrupted and not sufficient to decide if the frame was received correctly or not. To detect this fault type, the receiver additionally has to know the total frame length, including the number of stuff bits.

As a result, in case of Fault type B the frame CRC is not sufficient to decide if a frame was received correctly or not.

### Effect of fault type B on Classical CAN and CAN FD

Classical CAN is able to detect a single error of fault type B with a probability of 100%. To show this, two different cases have to be considered.

*Case 1:* In Classical CAN, if fault type B occurs at a stuff condition, this does not change the number of bits fed to the CRC algorithm in the receiving node. The receiving node sees a bit flip because in Classical CAN the dynamic stuff bits are not included in the CRC calculation. The frame CRC is sufficient to detect bit flips.

Example for shortening:  
 TX Bits 0 0 0 0 0 i  
 RX Bits 0 0 0 0 1 → from the CRC point of view: a bit flip at the 5<sup>th</sup> bit

Example for lengthening:  
 TX Bits 0 0 0 0 1 i  
 RX Bits 0 0 0 0 0 i → from the CRC point of view: a bit flip at the 5<sup>th</sup> bit

Legend  
 blue = bit used for CRC calculation  
 black = bit not used for CRC calculation  
 yellow = bit sampled more/less by the receiving node  
 i = recessive stuff bit

*Case 2:* If fault type B does not occur at a stuff condition, the received frame length changes and the CRC calculation is corrupted. The receiving node's view is shifted. In case of a single error, the erroneous frame is detected by the frame format checking, because at the end of the frame the receiving node sends its acknowledge either one bit too early or one bit too late.

### CAN FD version from 2014-08-12

CAN FD detects a single error of fault type B with a probability of less than 100%. To show this, two different cases have to be considered.

*Case 1:* In CAN FD, if fault type B occurs at a stuff condition, this does change the number of bits fed to the CRC algorithm in the receiving node by adding or removing a stuff bit. The CRC calculation is corrupted. Consequently, the frame CRC is not sufficient to decide if a frame was received correctly or not.

*Case 2:* If fault type B does not occur at a stuff condition, this does change the number of bits fed to the CRC algorithm in the receiving node by adding or removing a bit. The CRC calculation is corrupted. Additionally, the receiving node's view is shifted by one or more bits. If the ratio of data phase to arbitration phase bit-rate is large (e.g. 4 or larger),

it is possible that the frame format checking at the end of the frame (CRC delimiter and later) does not detect this shift, because the shift is very small compared to the duration of an arbitration phase bit time.

### Which cases need to be covered by the solution?

The residual error rate (Pres) of a communication system is an important attribute. Highly reliable systems require a very low Pres. Pres is a function of the undetected error rate (Pun) of a communication system and the necessary number of errors in a frame to achieve Pun. The more errors in a frame are necessary to achieve a  $Pun > 0$ , the lower is Pres.

The solution needed to improve CAN FD so that it has a lower Pres than Classical CAN. To achieve this CAN FD has to fulfill the following requirements:

- ◆ CAN FD has to detect frames with a single bit error with 100 % probability, i.e.  $Pun_{CAN\_FD} = Pun_{Classical\_CAN} = 0$ ;
- ◆ CAN FD has to detect frames with two bit errors with higher probability than Classical CAN, i.e.  $Pun_{CAN\_FD} < Pun_{Classical\_CAN}$ . This requirement was already fulfilled in the ISO/CD 11898-1 from 2014-08-12, as the critical bit sequence in CAN FD is much longer than in Classical CAN. The critical bit sequence consists of the bits in the CRC field. The receiving node uses these bits to check if it received the frame correctly.

Accordingly, the solution for the CRC issue needs to detect all single errors in a frame.

### Frame bit types

The bits in Classical CAN and CAN FD frames can be divided into two types.

*Type 1:* Key bits inform the receiver about how to interpret the remainder of the frame. The key bits in CAN FD are: IDE, FDF, res, BRS, and DLC. When one of these bits is sampled inverted in the receiving node, the receiver interprets the remainder of the frame differently than intended by the transmitting node. A frame with two or more falsified bits, where the first is a key bit, might be accepted by the receiving node as a valid frame. Such cases can be constructed in Classical CAN as well as in CAN FD.

*Type 2:* Non-key bits are all bits except the key bits. If the receiving node samples a non-key bit with inverted value, this has no impact on the interpretation of the remainder of the frame.

### Single errors that need to be considered

The solution needs to be able to detect all single errors in a frame. The following list is used to evaluate which single error cases need to be covered by the solution.

Fault type A – Bit flip:

- ◆ Key bit: The receiver gets misaligned, consequently the error is detected by the frame format checking. Probability = 100 %;
- ◆ Non-Key bit: The bit flip is detected by the frame CRC. Probability = 100 %.

Fault type B – Lengthening or shortening by 1 bit:

- ◆ One key bit is sampled inverted: The receiver gets misaligned, consequently the error is detected by the frame format checking. Probability = 100 %;
- ◆ All key bits are sampled correctly: The frame CRC is not sufficient to validate the frame. Probability < 100 %, which makes this a CAN FD CRC issue.

The CAN FD CRC issue may occur with fault type B only when all key bits are sampled correctly. The solution for the CRC issue needs to cover those cases where the frame is falsified by a single error that leads to fault type B, when in such an erroneous frame all key bits are still sampled correctly.

## Occurrence of the CRC issue

The CRC issue occurs when a CAN FD node (according to the ISO/CD 11898-1 version from 2014-08-12) does not detect a single error in a frame. Consequently it accepts the frame as valid. Both CRC polynomials (CRC-17 and CRC-21) used in CAN FD are affected. The issue can occur at the start of a frame and inside a frame.

## At the start of a frame

Cases with falsified Start-of-Frame (SOF) bits were first reported by engineers from Renesas. For these cases it is important to know that the ISO/CD 11898-1 version from 2014-08-12 defines the initialization value for the CRC registers as “0...0”.

*Case 1a - Shortening of frame:* A local error shortens the SOF bit at the receiving node. Now a frame starting with the identifiers “0000i” may be falsified to “0001”. Figure 4 visualizes the case.

In this case, the bus signal falsification has to be a local

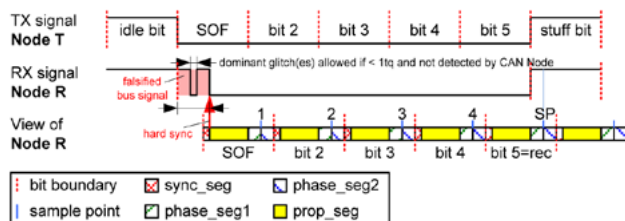

Figure 4: The five dominant bits (SOF + four identifier bits) are sampled as four dominant bits; the subsequent stuff bit is interpreted as a regular bit and not as stuff bit

error. This case can occur independently of the CAN clock frequency relation between transmitter and receiver, because the receiving node performs a hard synchronization at the beginning of the SOF bit. The falsified bus signal may contain dominant glitches, as long as each glitch is shorter than one time quantum and the glitches are not detected by the receiving CAN node.

The required shortening of the SOF bit depends on the CAN clock frequency relation between transmitter and receiver. If the nodes do not have any CAN clock tolerance ( $df = 0\%$ ) then a shortening/falsification of the SOF bit by “phase\_seg2 +  $\epsilon$ ” is sufficient to create the case. At 1 Mbit/s and a sample point of 80 %, a shortening by 205 ns is sufficient.

*Case 1b - Lengthening of frame:* A local error lengthens the SOF bit at the receiving node. The lengthening occurs

# Kvaser supports 5 CAN channels

## KVASER MEMORATOR PRO 5xHS

An interface and datalogger that greatly simplifies multichannel CAN data capture.

[www.kvaser.com/memoratorpro5](http://www.kvaser.com/memoratorpro5)



## 5 CHANNEL USBCAN INTERFACE

Launches May 2015

Find CAN hardware  
and software at

[www.kvaser.com](http://www.kvaser.com)

YOUR PORTAL TO THE  
PERFECT CAN SOLUTION

towards the bit before the SOF bit. Now a frame starting with the identifiers "0001" may be falsified to "0000i". Figure 5 visualizes the case.

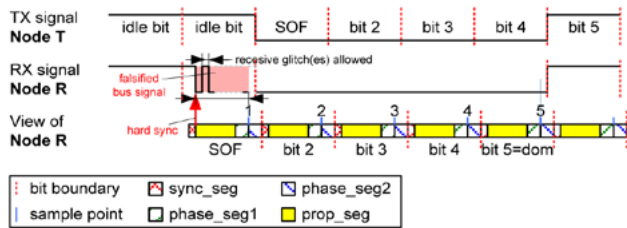

Figure 5: The four dominant bits (SOF + three identifier bits) are sampled as five dominant bits; the subsequent recessive bit is sampled as a stuff bit

In this case, the bus signal falsification has to be a local error. This case can occur independently of the CAN clock frequency relation between transmitter and receiver, because the receiving node performs a hard synchronization at the beginning of the SOF bit. The falsified bus signal may contain recessive glitches, as long as the bit prior to the SOF bit transmitted by the transmitter is sampled as dominant by the receiving node.

Inside a frame

A falsified "0" bit sequence is detected wrongly if it starts when the intermediate CRC register value equals "0...0". The case can occur at any bit position in between SOF bit and the transmitted CRC checksum. A simple way to construct cases is to exploit the following two facts: Firstly, the intermediate CRC register value may be "0...0" during the reception of a frame. Secondly, in case the intermediate CRC register value is "0...0", then an incoming 0 (dominant bit) does not change the intermediate CRC register value, while a 1 (recessive bit) does change it.

Case 2a - Shortening of frame: The receiving node samples the bit sequence "00000i" as "00001". Figure 6 visualizes the case.

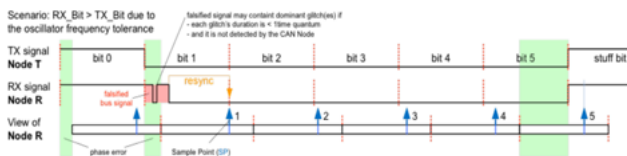

Figure 6: The receiving node samples the bit sequence "00000i" as "00001"

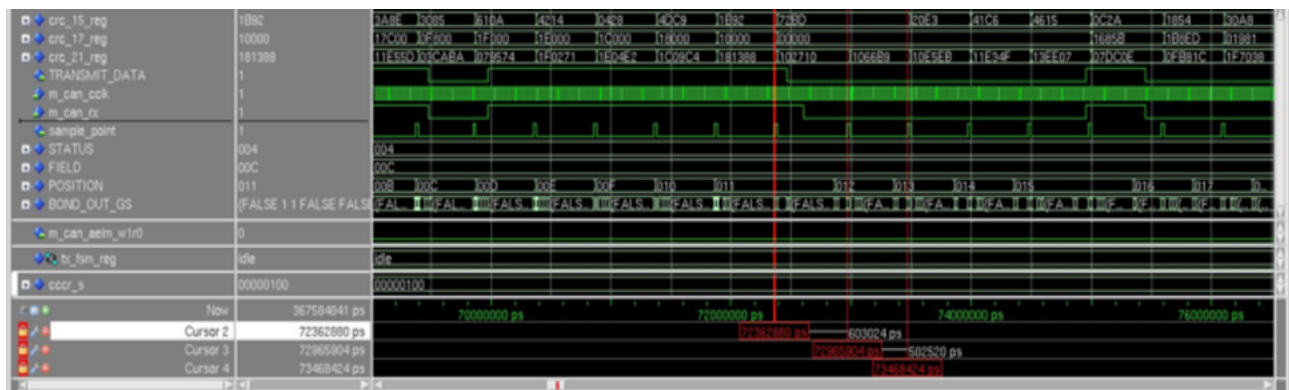

Figure 7: The signals "m\_can\_rx" and "sample\_point" are especially interesting

The transmitting node sends the stuffed bit sequence "00000i". An error shortens the first "0" of this bit sequence. The receiving node resynchronizes on this "wrong" edge.

The intermediate CRC register value has to be "0...0" at the first bit of this sequence. The receiving nodes samples "00001". This means it samples four "0" bits instead of five. The falsification of the bus signal leads to no correction of the phase error, or even a correction into the wrong direction.

This case may occur, if BitTimeRX\_node > BitTimeTX\_node due to clock tolerance and if the sample point position in the receiving node is late (e.g. 80 %). The bus signal falsification can be a local error if the transmitting node uses no transmitter delay compensation, or a global error if the transmitting node uses transmitter delay compensation.

This case was reproduced in simulation. Figure 7 shows a simulation screenshot of this case. Focus on the signals "m\_can\_rx" and "sample\_point".

Case 2b - Lengthening of frame: The receiving node samples the bit sequence "00001" as "00000i". Figure 8 visualizes the case.

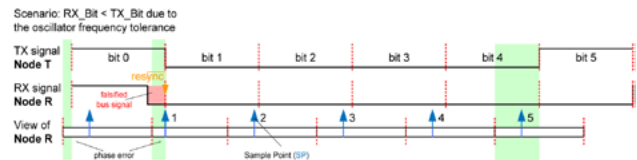

Figure 8: The receiving node samples the bit sequence "00001" as "00000i"

The transmitting node sends the unstuffed bit sequence "00001". An error lengthens the first "0" of this bit sequence. The receiving node resynchronizes on this "wrong" edge. The intermediate CRC register value has to be "0...0" at the first bit of this sequence. The receiving nodes samples "00000i". This means it samples five "0" bits instead of four. The "1" in this bit sequence is interpreted as a stuff bit. The falsification of the bus signal leads to no correction of the phase error, or even a correction into the wrong direction.

This case may occur, if BitTimeRX\_node < BitTimeTX\_node due to clock tolerance and the sample point position in the receiving node is early (e.g. 20 %). The bus signal falsification can be a local error if the transmitting node uses no transmitter delay compensation, or



a global error if the transmitting node uses transmitter delay compensation.

## Solving the CRC issue

To solve the CRC issue, the receiving node needs to know the total number of transmitted bits for each frame. The receiving node already knows the total frame length excluding dynamic stuff bits from the received frame type and the DLC. Therefore the number of dynamic stuff bits (generated by the Classical CAN stuffing method) is included into the frame format.

It is sufficient to transmit the stuff bit count modulo 8. With this it is possible to detect up to seven lengthening or shortening errors, if these coincide with stuff conditions. This is adequate as we consider a Hamming distance of 6 for CAN FD.

The stuff bit count is transmitted in the first bits of the CRC field, lengthening this field. This position was chosen for two reasons:

Firstly, the stuff bit count needs to be transmitted after switching from dynamic bit stuffing to fixed bit stuffing. In the CRC field the fixed stuff bit method has to be used. At the beginning of the CRC field the nodes know the total amount of dynamic stuff bits in the frame.

Secondly, the stuff bit count needs to be transmitted before the CRC sequence in order to be safeguarded by the frame CRC.

When a stuff bit is dropped or inserted by synchronization failure, the CRC is corrupted. This means the receiver

may not be able to detect this error with the help of the frame CRC. When a bit flip falsifies the stuff bit count in the same frame, the receiver may not be able to detect this error.

This makes it necessary to safeguard the transmitted length information itself, i.e. the stuff bit count modulo 8. This is done through the following two safeguards:

- ◆ Adding a parity-bit (even parity);
- ◆ Gray-coding the stuff bit count.

Table 1: New bits added to the FD frame format and coding of the eight possible stuff bit counts modulo 8

Stuff bit count modulo 8	Bits added to FD frame format		
	Gray-coded value	Parity bit	Fixed stuff bit
0	000	0	1
1	001	1	0
2	011	0	1
3	010	1	0
4	110	0	1
5	111	1	0
6	101	0	1
7	100	1	0

Since the stuff bit count is inserted at the beginning of the CRC field, there is a fixed stuff bit following the parity bit, with the inverse value of the parity bit. Parity check and fixed bit stuffing rules detect any single bit flip of these bits. The same applies for two bit flips if at least one of the bit flips is the parity bit or the following fixed stuff bit. If two bits of the

We live electronics!  
We live electronics!

sontheim  
Industrie Elektronik GmbH



## COMhawk® - the On-Board system for efficient telematics and diagnostics

This high-performant electronic control unit has numerous applications for communication and diagnostics on machines including its use as a CAN-to-Wi-Fi Gateway, data server, telemetry node, data logger or diagnostic device.

- ▶ 32bit controller with 3x CAN, Wi-Fi, Ethernet, optional I/Os, built-in diagnostic functions and a webserver interface
- ▶ Future-proof freely programmable and real-time capable ECU system
- ▶ Record CAN-messages on built-in NAND-Flash-Memory of up to 16GB
- ▶ Designed for harsh environments: IP69k, heat cycle and vibration tested according to the Automotive EMC Directive
- ▶ Temperature range up to 85°C

Sontheim Overview and Portfolio:



- ▶ Searching for a matching diagnostic tool? Have a look at:

[www.s-i-e.de/en/products/diagnostics/mdt](http://www.s-i-e.de/en/products/diagnostics/mdt)



All highlights of COMhawk.

We live electronics!  
www.sontheim-industrie-elektronik.de

DE Sontheim Industrie Elektronik GmbH  
Georg-Krug-Str. 2, 87437 Kempten  
Tel: +49 831 57 59 00 -0 - Fax: -73  
info@s-i-e.de

US Sontheim Industrial Electronics Inc.  
One West Court Square, Suite 750  
Decatur, GA 30030  
Phone: +1 (404) 494-7839 - Fax: -7701

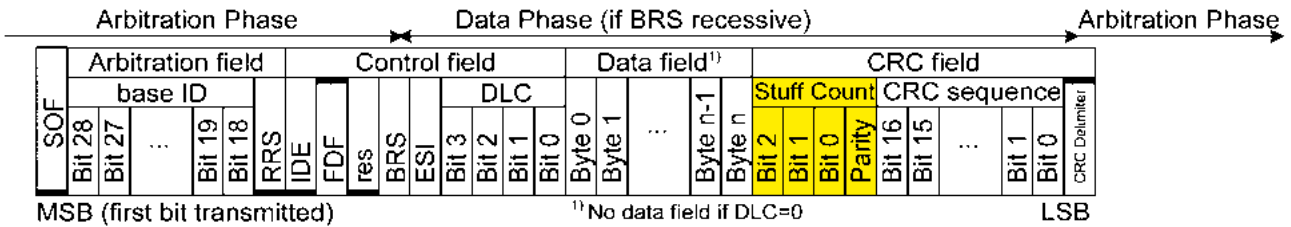

Figure 9: Order of bit transmission in FD base frame format; up to 16 data bytes

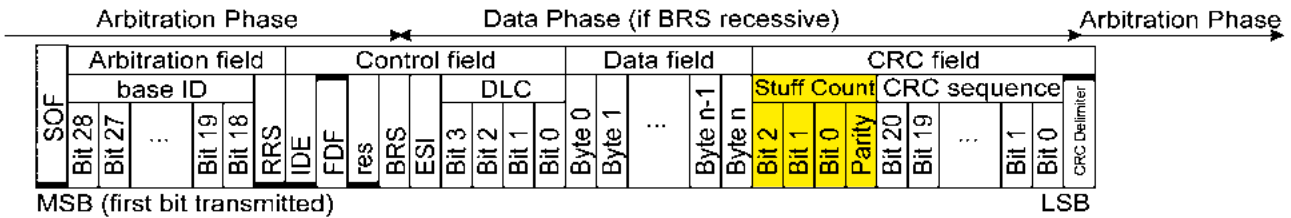

Figure 10: Order of bit transmission in FD base frame format; 20 to 64 data bytes

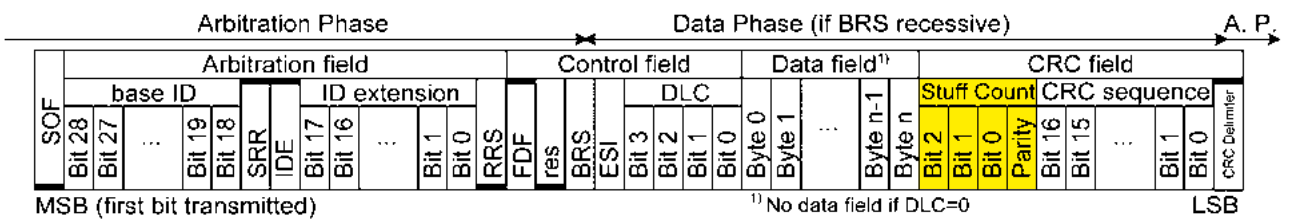

Figure 11: Order of bit transmission in FD extended frame format; up to 16 data bytes

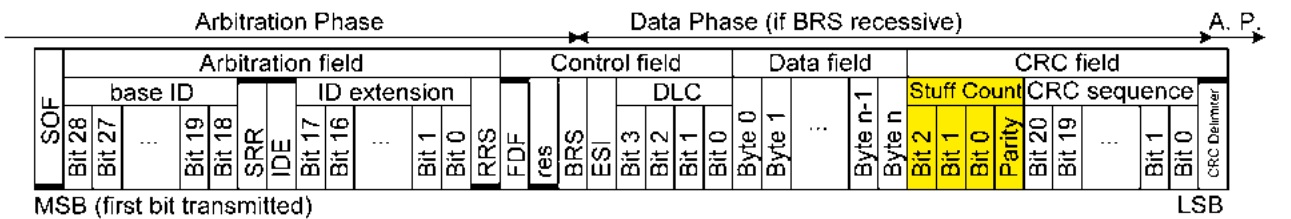

Figure 12: Order of bit transmission in FD extended frame format; 20 to 64 data bytes

gray-coded stuff bit count are flipped, the results is a stuff bit count value with a difference of at least 2, which is detected by a comparison with the internally counted stuff bit value. The minimum number of bit errors that could remain undetected is four, when two bit flips in the gray-coded stuff bit count coincide with two dropped or inserted stuff bits.

CRC17, Stuff count = 0	S00001CCCCSCCCSCCCSCCCSC
CRC21, Stuff count = 0	S00001CCCCSCCCSCCCSCCCSCCCSC
CRC17, Stuff count = 3	S01010CCCCSCCCSCCCSCCCSC
CRC21, Stuff count = 3	S01010CCCCSCCCSCCCSCCCSCCCSC

Legend: **red**: fixed stuff bit,  
**C**: CRC bit,  
**shaded**: the 5 new bits inserted to the CAN FD frame

Figure 13: Exemplary bit sequences

The receiver checks the received stuff bit count modulo 8 by comparing the received value with the internally counted value and the parity bit by comparing the received value to the internally calculated value. A mismatch during the comparison is treated the same way as a detected CRC error.

The ISO Task Force also decided to use “10...0” as an initialization vector for CRC-17 and CRC-21. The single “1” is at the most significant bit position. The old initialization vectors were all “0...0”. With this new initialization vector an intermediate CRC register value of “0...0” cannot occur for the

first 17 transmitted bits with CRC-17 and for the first 21 transmitted bits with CRC-21.

### Changes to the CAN FD frame formats

Figure 9, 10, 11, and 12 show the resulting FD frame formats. The figures do not show stuff bits; changes are highlighted yellow. The part of the CRC field that contains the stuff bit count modulo 8 and the parity bit is named Stuff Count.

Figure 13 shows exemplary bit sequences of the CRC field. Recall that the CRC field starts with a fixed stuff bit. Then a fixed stuff bit is inserted after each 4 bits of the CRC field. The Stuff Count has 4 bit. In total, the CAN FD frame is lengthened by 5 bits, since after 4 bits a fixed stuff bit is inserted into the CRC field.

#### Author

Dr. Arthur Mutter  
 Robert Bosch GmbH  
[www.bosch.de](http://www.bosch.de)



ifm electronic



Your vehicle can see more  
than you think...



Visit us at  
Hannover Messe 2015  
► hall 9 · stand D36

...now you can see it too –  
at a glance.

PDM360 NG-12 dialogue module for mobile machines. Optimum readability thanks to bright 12.1" TFT display with 1024 x 768 pixels and "optical bonding". Backlit function keys with tactile feedback.  
Powerful 32-bit controller, freely programmable to IEC 61131-3 with CODESYS.  
Internal mass memory and interfaces for USB, Ethernet, CAN and analogue cameras.



[www.ifm.com/gb/12inch](http://www.ifm.com/gb/12inch)

Phone: +49 0800 16 16 16 4

## Swift but sensitive movements

*The less a forestry crane swings and jerks, the quicker the machine's operator can move tree trunks from one position to another. Hydraulic solutions can make sure the swivel and arm movements are continuous.*



Instrumental for a good hydraulic solution are proportional directional spool valves with a load-sensing system. They implement the crane operator's commands finely and sensitively, irrespective of the load's weight. The main arm, articulated arm, telescope, swivel arm, rotator and gripper all move according to the operator's wishes, without start-up jerks or unwanted interruptions in the movements. Challenges for the technical implementation of the hydraulic solution are the pulling loads. Pulling loads often trigger uncontrolled movements during lowering velocities that are independent of the load. This is particularly noticeable in situations where the influence exerted by the force of gravity is reversed. The crane arm's dead weight accelerates its movements towards the lower dead center, while movements away from the dead center require hydraulic support. In practice, uncontrolled movements affect above all the precise buckling movements close to the posts or fast swivel movements downhill.

Hydraulic controls with standardized valves often arrest the articulated arm briefly before jerking back into action, which leads to inconvenient judders during swiveling. To prevent this, Hawe Hydraulik from Munich has developed special spool valve types that enable fine and jerk-free movements. To select the appropriate type, the hydraulics specialists from the company liaise closely with the customer to determine the necessary counter pressures for sensitive acceleration and deceleration. A special program determines reliably and in advance the valve

characteristics for different cylinder sizes and ratios of the crane's arm, irrespective whether the proportional directional spool valve is being actuated manually, hydraulically, electro-hydraulically, or via a CAN interface. There is no need for a reworking and subsequent testing of the spool valve piston. The valves are fitted with a spool valve piston according to the findings calculated by the program. This piston is fine-tuned to the application's cylinder parameters and has an exactly defined fine-control zone that allows the operator to handle the tree trunks as easily and conveniently as possible. The modular product kit includes numerous types of spool valves to cover a range of pressure ratios. ▶



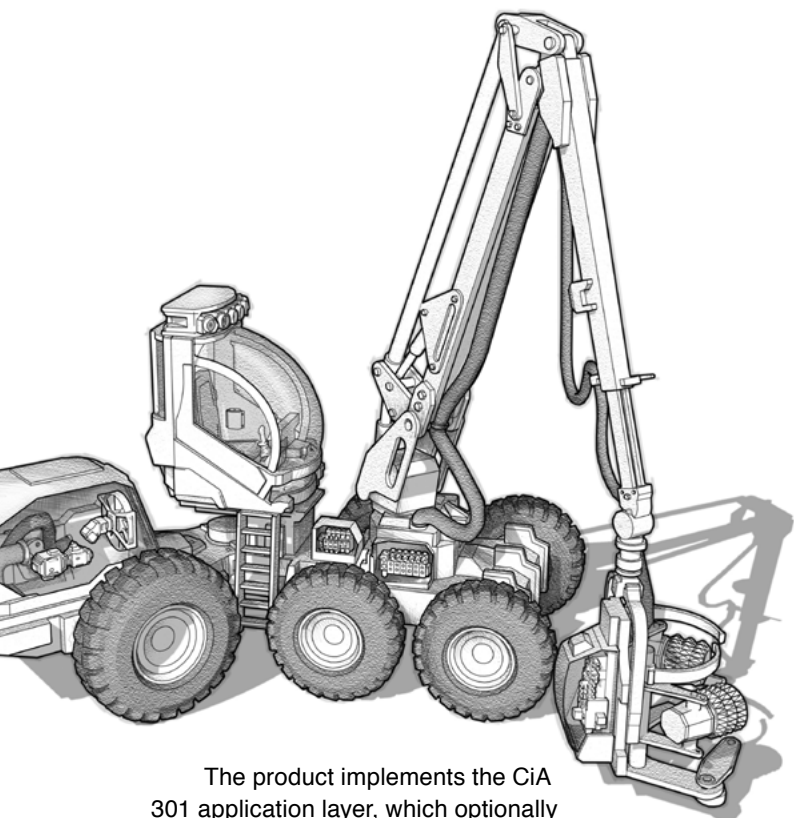

The product implements the CiA 301 application layer, which optionally allows the use of 29-bit identifiers. It supports the CiA 408 CANopen profile for fluid power control as well as, on customer request, the CiA 401 CANopen profile for I/O modules. The default bit-rate is 250 kbit/s but 50, 100, 125, 500, and 1000 kbit/s are also possible. The busload is 30 % and the standard SDOs and PDOs with the required status update, setpoints, and process data messages are sent. The following participants are plugged into the network: usually a master-controller and CAN valves of the type PSL (proportional directional spool valves) of Hawe. Depending on the application, sensors, displays, joysticks, and input devices can also be plugged into the CAN network.

### Saving fuel

Juddering movements and the correction of these movements takes up fuel. However, where proportional and load-sensing technology is used, this is not an issue anymore, as the machine operator can position all axes of the crane exactly and finely and it thereby consumes less diesel fuel. Special spool valve pistons with regenerative functions for lifting the articulated arm and extracting the telescope also help to improve the energy balance. Thus, the oil from the rod end is co-used when the cylinder is extracted. Instead of feeding it back into the tank it is forwarded directly across to the piston end. Consequently, the pump's required residual amount is low.

The regenerative spool valve piston reduces the hydraulic consumer's volume flow demand, which makes the system not only energy-efficient but also protects it against oil shortage. Valves with regenerative spool valve pistons are therefore particularly interesting for hydraulic systems using small pumps and cylinders with large piston area ratios. Alongside the regenerative spool valve pistons, Hawe Hydraulik also offers special anti-shock and anti-cavitation valves. With these, the lowering movement is executed mainly by the load's dead weight and thus saves fuel.



Pioneering new technologies  
Pioneering new technologies



Sensor-Technik Wiedemann GmbH  
Mobile Controllers and Measurement Technologies

## 32 bit electronic control unit ESX®-3XL



- 32 bit controller with max. 136 I/Os and 4 × CAN
- freely programmable in „C“ and CODESYS
- certified for safety applications (SIL2, PLD)
- including Memory Protection

## Pressure transmitter with thin-film measuring element



- pressure ranges from 0 ... 10 bar to 0 ... 2000 bar (Overall accuracy in the temperature compensated range: 1%)
- max. media temperature 150°C / max. ambient temperature 125°C
- wetted parts and case in stainless-steel
- CAN-Bus interface

### Exhibitions



Hannover Messe, Hanover  
13.04. – 17.04.2015  
Hall 11, Booth E34



Sensor + Test, Nuremberg  
19.05. – 21.05.2015  
Hall 12, Booth 604

**Sensor-Technik Wiedemann GmbH**  
Am Bärenwald 6 · 87600 Kaufbeuren  
Germany  
Telephone +49 8341 9505-0



Figure 1: One control block with PSL proportional directional spool valves serving six crane functions



Figure 3: The V40M axial piston pump's pivoting angle enables exact rate settings



Figure 2: The axial piston pump V60N-130 offers default overload protection for the gearbox



Figure 4: The sturdy die-casted housing makes the PLVC electronic valve control suitable for outdoor applications

The anti-cavitation valves are built to enable a high volume of anti-cavitation volume so that air does not enter the system and all functions can be constantly executed.

### Tailor-built pumps

Adjustable axial piston pumps with power controllers are also sparing on the fuel demand of the forestry crane. They only supply oil when needed and in the quantity required. The pump is not constantly working at a maximum pivoting angle but adjusted to the current demand of the hydraulic consumer. This makes the system efficient and limits heat generation. The load-sensing and pump channel of the load-sensing controller are arranged so that no pressure is lost when transmitting the load signal. This is of particular interest for forestry cranes as the dynamic between pump and control block remains strong even at distances spanning multiple meters. The stand-by pressure can be

set comparatively low, which in turn cuts down diesel fuel consumption. Even if the fitting tolerance increases with the years, the customer does not have to take recourse to additional "copying valves" to reinforce the load-sensing signal. The operator benefits from the patented "dynamic throttle", which serves for easy and convenient setting of the optimal ratio between vibration dampening and dynamics.

The pump portfolio of the company offers pressurized oil supply solutions tailored to individual requirements for operating pressures of up to 400 bar and peak pressures of up to 450 bar. Multiple sizes and designs built according to the swashplate construction principle provide the required displacement volume without over- or under-dimensioning the pump output. In addition, controls enable the hydraulic solution to support the energy efficiency of mobile machines and thereby compliance with such emission regulations as Tier 4 and Euro 6. For displacement volumes up to 130 cm<sup>3</sup>/cycle and peak pressures up to

450 bar, the V60N-130 axial piston pump comes into play. This pump offers a default overload protection for the vehicle's gearbox. Its width measures merely 130 mm and it is housed in a stable casing protecting it against torsional deformations. Where less power suffices the V40M axial piston pump is a suitable choice. The pivoting angle enables exact and fine flow rate settings going up to 45 cm<sup>3</sup>/cycle. At a self-suction speed of 2900 revolutions per minute, it is suited for applications requiring operating pressures of up to 250 bar that can also experience peak pressures of up to 320 bar. With a length of 208,5 mm, it is particularly well suited for deployment as a twin pump in machine housing.

### Faultless valve actuation

Crane operators require their commands to be safely and faultlessly transmitted to the hydraulic valves. To this end, a number of different actuation controls are available: hydraulic or manual, electro-hydraulically or via a CAN network. Though the hydraulic and manual versions do not require servicing, they cannot offer as much operating comfort as the electro-hydraulically controls. The latter supports finer realization and more precise movements, no matter how the crane operator handles the joystick. Its key advantage is above all that it can be individually adjusted to the user. Where multiple operators work with a crane, it can store user profiles with driver-specific characteristics. Moreover, twin solenoids make the electro-hydraulically controls unsusceptible to electro-magnetic interference. Valve controls with a CAN interface improve the movements' precision as they constantly monitor the position of the spool valve piston and thereby adjust the volume flow exactly to the consumer's actual demand. In addition, the CAN technology supports the sensitive movements by removing hysteresis. Hydraulic functions differ between loading crane, harvester crane or skidder crane. Yet, they share the same demand for swift, sensitive and energy-efficient work operations. ◀

### Authors

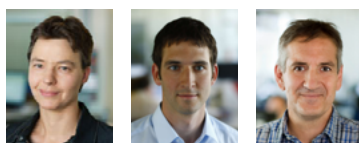

Ulrike Ballnath, Tobias Kohler, Ralf Mebert  
 Hawe Hydraulik SE  
[info@hawe.de](mailto:info@hawe.de)  
[www.hawe.de](http://www.hawe.de)

# QNX and PREEMPT\_RT Linux

the stable and reliable real-time platform for embedded & distributed systems

**CAN | CANopen® | J1939**

## DACHS® Distributed Automation Control System

### Standard DACHS® products for CAN

- CAN Layer2, CANopen, and J1939 in real-time
- high performance drivers and APIs
- CANopen stack with sources
- IEC 61131-3 / IEC 61499 programming
- **DACHSVIEW++** with C/C++ JIT Compiler

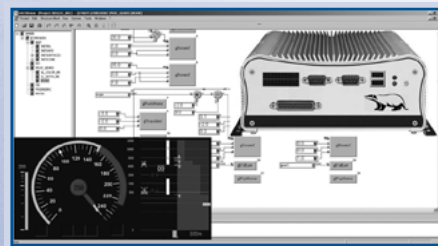

### supported boards:

PC/104, PC/104-Plus, PCI, PCIe, ISA, SoCs

### supported CAN controllers:

SJA 1000, i82527 or Bosch CC770, msCAN, HECC, TouCAN, etc.  
 for x86, PPC, ARM9, etc.

OEM solutions and adaption for OEM platforms

CONSULTING & ENGINEERING



+49 (0)64 31-52 93 66 · [info@steinhoff-automation.com](mailto:info@steinhoff-automation.com)  
[www.steinhoff-automation.com](http://www.steinhoff-automation.com) · [www.dachs.info](http://www.dachs.info)

**FLEXIBLE | RELIABLE | INNOVATIVE | EMBEDDED**  
**PC-BASED | REAL-TIME | FIELDBUSES**

DACHS® Product Suite, support worldwide, consulting & engineering  
 DACHS and the DACHS logo are registered trademarks of Steinhoff A.  
 All other trademarks belong to their respected owners.

# Stand-by transceiver with fail-safe features

Atmel has launched a series of high-speed transceiver chips for CAN FD networks, which optionally provide low-power capability. The fail-safe features include over-temperature protection.

The AEC-Q100-qualified ATA6560 and ATA6561 transceiver chips are suitable for bit-rates up to 5 Mbit/s. The ATA6561 offers a direct interface to MCUs with 3-V to 5-V supply voltages. Various operating modes together with dedicated fail-safe features make the chips suitable for next generation in-vehicle networks, especially for CAN FD nodes requiring a low-power mode. The products are available in SO8 and DFN8 packages with wettable flanks for automated optical solder inspection. The specified temperature range is -40 °C to +150 °C. “Our new family of CAN transceivers enables our OEMs to bring improved connectivity with higher speed in their automobile with overall lower power,” explained Claus Mochel, Atmel Marketing Director for Automotive High Voltage Products. “We are continuing to expand our automotive product portfolio to give our customers the right mix of products to help shorten their design cycle and bring next-generation designs faster to market.”

## Operating modes include an unpowered mode

Both transceivers support a normal, a stand-by, and an unpowered mode. The ATA6560 additionally provides a silent mode. In the unpowered mode, the chips are completely disengaged. In the normal mode, the driver stage is active and drives data from the TXD input to the CAN bus lines. The high-speed comparator (HSC) converts the analog data on the bus lines into digital data, which is output to the RXD pin. The bus biasing is set to  $V_{CC}/2$  and the under-voltage monitoring of the power supply is active. The slope of the output signals is controlled and optimized in such a way that it leads to a low electromagnetic emission.

In the stand-by mode, the transceiver cannot transmit or correctly receive data via the CAN bus lines. The transmitter and the HSC are switched off in order to reduce power consumption and only the low-power wake-up comparator (WUC) monitors the bus lines for a valid wake-up signal. A signal change on the bus from recessive to dominant followed by a dominant state longer than  $t_{wake}$  switches the RXD pin to low in order to signal a wake-up request to the connected micro-controller. In the stand-by mode, the bus lines are biased to ground, in order to reduce the current consumption to a minimum. When the transceiver signals a wake-up request to the micro-controller, a transition to normal mode is not triggered until the micro-controller sets the related signal. A bus dominant time-out timer prevents the transceiver from generating a permanent wake-up request. The ATA6560 additionally causes a quiescent current from VIO to GND by means of an internal pull-up resistor when the silent mode is activated.

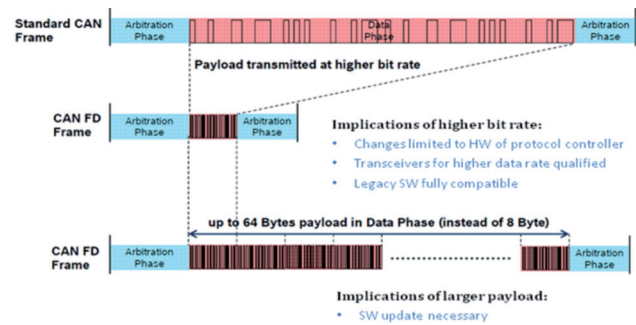

Figure 1: Operating modes of the ATA656X series (Source: Bosch)

The silent mode, only available on the ATA6560, can be used to test the connection of the bus medium, for example. In this mode the transceiver can still receive data, but the transmitter is disabled. The bus pins are released to a recessive state. All other transceiver functions, including the HSC, continue to operate as they do in normal mode. The silent mode can also be used to prevent a faulty CAN controller from disrupting the entire network communication.

## Fail-safe features include under-voltage detection

The transceivers feature several fail-safe functions, in order to improve the robustness of the communication. This includes the TXD dominant time-out function. The related timer is started when the TXD pin is set to low. If the low state persists for longer than 0,8 ms, the transmitter is disabled, releasing the bus lines to recessive state. This function prevents the bus lines from being permanently driven to dominant state. The timer is reset when the TXD pin is set to high.

Pull-up resistors for the TXD, STBY, and NSIL pins ensure a safe, defined state in case the pins are left floating. Pull-up currents flow in these pins in all states, meaning all pins should be in high state during stand-by mode to minimize power consumption. If VCC and VIO drop below the under-voltage level, the transceiver switches off. The low-power WUC is only switched off during under-voltage. In stand-by mode, the wake-up time-out timer is started when the bus changes from the recessive to the dominant state. If the dominant state persists for a specified time (see above), the RXD pin is switched to high. This prevents a permanent clamping to dominant state, due to a short-circuit or a failure in one of the other nodes, which would cause a permanent wake-up request. The bus wake-up time-out timer is reset when the bus changes from dominant to recessive state.



### SENSORS FOR MOBILE MACHINES

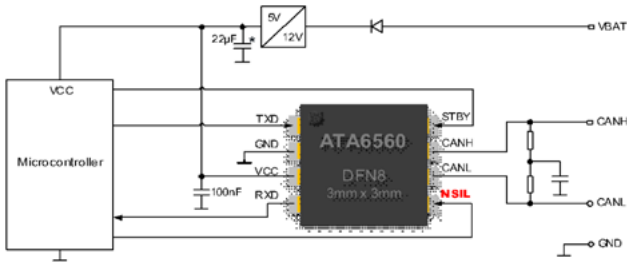

Figure 2: Typical application circuitry using the ATA6560 (Source: Atmel)

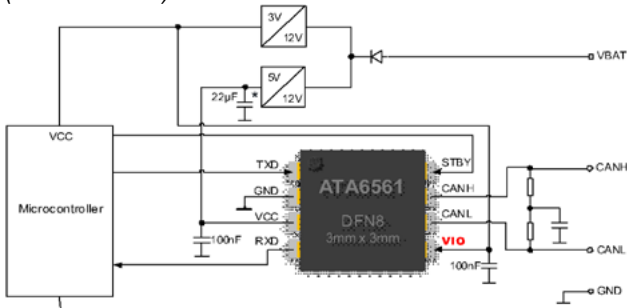

Figure 3: Typical application circuitry using the ATA6561 (Source: Atmel)

The output drivers are protected against over-temperature conditions. If the junction temperature exceeds the specified shutdown value (150 °C), the output drivers are disabled until the junction temperature drops and the TXD pin is at a high level again. The TXD condition ensures that output driver oscillations due to temperature drifts are avoided. Additionally, a short-circuit protection of the bus pins against GND and positive supply voltages is provided. A current-limiting circuit protects the transceiver from damage. If the transceiver heats up due to a continuous short between the bus-lines, the internal over-temperature protection switches the transmitter off.

The RXD recessive clamping function prevents the transceiver from sending data on the bus if its RXD line is clamped to high. If the RXD pin cannot signalize a dominant bus condition (because it was shorted to VCC) the transmitter is disabled to avoid possible data collisions on the bus. In normal and silent mode, the chips permanently compare the state of the HSC with the state of the RXD pin. If the HSC indicates a dominant state for more than 90 ns without the RXD pin doing the same, a recessive clamping situation is detected and the transceiver is forced into silent mode. This mode is released by either entering stand-by or unpowered mode or if the RXD pin shows a dominant level again.

### Following transceivers will support partial networking

Atmel considers supporting partial networking as defined in ISO 11898-6 in future transceiver products. With this feature it will be possible to wake up CAN nodes individually. Transceivers with this selective wake-up capability need to partly implement the CAN protocol. A conformance test plan is being internationally standardized for partial networking transceivers (ISO 16845-6). The ISO standards for CAN high-speed transceivers (ISO 11898-2, ISO 11898-5, and ISO 11898-6) are currently under review and will be merged into one single document.

Holger Zeltwanger



### Absolute Rotary Encoders and Inclinometers

#### Reliable Measurement under Harsh Conditions

High Protection Class: IP69K

Fieldbus and Analog Interfaces

Safety and ATEX

Ex-Proof Versions Available

Successfully Integrated in  
Concrete Pumps, Drilling Machines,  
Working Platforms, Cranes, Wheel Loaders,  
Leader Masts and More

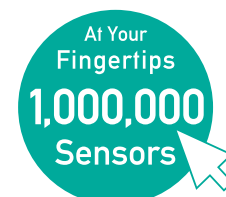

[www.posital.com](http://www.posital.com)

# Sensor fusion is on the agenda

*Carmakers have been using sensor fusion for years. Academics provided the theory, chipmakers offered the required software. From now on, other vehicles can use sensor fusion, too.*

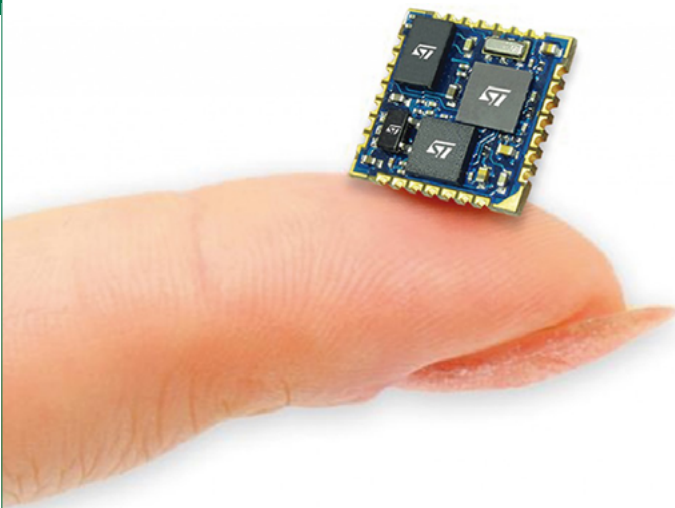

*Figure 1: The iNemo-M1 is a 9-axis sensor module combining gyroscope, accelerometer, and magnetometer with a 32-bit micro-controller running the sensor fusion software developed with the iNemo software suite (Photo: ST-Microelectronics)*

In general, sensor fusion is nothing new. Mother Nature uses it: snakes combine visual data from the eyes with smell information from their forked tongue and temperature information from their infrared-sensitive receptors. This is necessary to track and catch prey, because they can't focus their eye lenses. Also in technical systems, combining data from different sensor elements and generating new information has been state-of-the-art for many years. For example, combining pressure sensors with temperature sensors allows us to evaluate the measured pressure in the sensor device. The use of redundant sensor elements is an old technology: just think of stereoscopes. And don't forget your smartphone, your tablet computer, and your digital camera. They all implement sensor fusion technology.

Sensor fusion as it is used in the automotive industry has lifted fusion technology to a new level. Besides direct fusion, which is a fusion of data from a set of heterogeneous or homogeneous sensors, soft sensors, and history values, there is also indirect

fusion. Indirect fusion uses information like a priori knowledge about the environment and processes as well as human input. Of course, both kinds can be combined.

Automated driving was one of the driving forces behind the improvement of sensor fusion technologies. An example is the computing of the orientation of a car on the road's lane or in relation to other vehicles or even pedestrians. ADAS (Advanced Driver Assistance Systems) use them heavily. How much automotive suppliers expect from the market can be seen from the investments they have made: Since 2011, for example, Bosch has employed about 5000 engineers in Palo Alto (California) and Abstatt (Germany) developing technologies for automated driving.

Automated driving affects every aspect of the car – powertrain, brakes, steering. It is based on sensors featuring radar, video, and ultrasound technology. “Sensors are the eyes and ears that let vehicles perceive their environment,” said Dr. Dirk Hoheisel, who sits on the company's board of management.

## MEMS make sensor fusion affordable

Micro-electromechanical systems (MEMS) are the building blocks of sensor fusion. MEMS-based sensors are available from different manufacturers. Low-cost MEMS for accelerometers and gyroscopes are useful for position sensing and when fused together result in pitch and roll accuracy over a broad frequency range. They can be used for dead reckoning, medical devices, robotics, and industrial machine control. A typical application is an inertial

measurement unit (IMU) comprising a three-axis gyroscope, an accelerometer, and a magnetometer. The IMU needs to fuse the data of the sensor elements. MEMS are also used for attitude and heading reference systems (AHRS). Magnetic distortion problems caused by steels, permanent magnets, or electric currents have been solved in the last years.

Different fusion methods exist: the evaluated average, Bayes' theorem (see insert “Bayes' theorem”), the Kalman filter (see insert “Kalman filter theory”), Fuzzy algorithms, and least squares. All of them require computing power by means of Floating Point Units (FPU) or Digital Signal Processors (DSP). ▶



*Figure 2: The LPMS-CU is an inertial measurement unit and attitude heading reference system comprising three different 3-axis MEMS (gyroscope, accelerometer, and magnetometer), which provides CAN connectivity (Photo: Life Performance Research)*

The Autonet 2030 project, supported by Hitachi and the Technical University of Chemnitz (Germany), has developed a multi-sensor fusion concept for plausibility checking of vehicle-to-vehicle communication by vision-based multiple object tracking. The project uses a Mobileye front camera and an Atheros AR541A-B2B-based communication device. Moreover, this data is fused with the yaw rate and velocity data from the CAN in-vehicle network. The probabilistic data fusion among these sensors is implemented with the Baselabs framework for ADAS.

### Software support from chipmakers

Sensor fusion is based on software. Sensor data has to be combined for example to calculate accurate positions and orientations. Sensor fusion software runs on normal MCUs that often provide CAN connectivity. Today's 8-byte payload limitation of CAN messages will no longer be a limiting factor when CAN FD hardware with up to 64-byte data fields becomes available. Chipmakers are committed to sensor fusion and have developed dedicated software packages.

Sensor fusion algorithms are important to compensate undesired effects. For accelerometers in AHRS, for example, there is no difference between gravity and lateral acceleration. Lateral acceleration needs to be properly compensated, otherwise the roll and pitch values are incorrect. Sensor fusion algorithms also need to detect magnetic distortions.

Freescale provides the Xtrinsic suite of sensor fusion tools for its ARM-based Kinetis MCU family featuring CAN connectivity. The current version is based on the Code-Warrior software development environment. Users can download a free node-locked version for evaluation and development. With pre-compiled sensor fusion application templates, users can experiment before beginning the application software development. ▶

### Kalman filter theory

Kalman filtering is a recursive algorithm, which is suitable for the fusion of noisy data. It estimates the state of a system at a time by using the state of a previous time. A common application is sensor fusion for navigation and guidance of vehicles. The Kalman filter calculates estimates of the true values of states recursively over time using the measured values and a mathematical process model (transition and observation matrixes). Kalman filters are also used in robot motion control applications. The algorithm works in a two-step process. In the prediction step, the Kalman filter produces estimates of the current state variables, along with their uncertainties. Once the outcome of the next measurement (necessarily corrupted with some amount of error, including random noise) is observed, these estimates are updated using a weighted average, with more weight being given to estimates with higher certainty. The Kalman filter can be regarded as a simple dynamic Bayesian network (see insert "Bayes' theorem").

# SPRING OFFER!

save up to **300 €\***  
until **May 2015!**

(\*50 € per license, use code: "spring")

## Fieldbus diagnostics



# GEMAC

[www.gemac-chemnitz.de](http://www.gemac-chemnitz.de)



Figure 3: The PCAN-GPS is a CAN-connectable sensor module based on NXP's LPC4000 micro-controller comprising a GPS receiver, a magnetometer, an accelerometer, and a gyroscope (Photo: Peak-System Technik)

ST-Microelectronics offers the iNemo engine software suite, which comprises filtering and predicting algorithms. This includes algorithms to integrate outputs from multiple MEMS sensors. The software can be used with iNemo inertial modules to create multi-axis MEMS sensor solutions for motion and heading recognition. Equipment manufacturers across different market segments can deploy motion detection systems with up to 10 degrees of freedom, comprising 3-axis sensing of linear, angular, and magnetic motion with barometer/altitude readings from a pressure sensor. Of course, the software supports Kalman filtering. The generated firmware runs on STM32 micro-controllers.

Atmel has partnered with sensor manufacturers and sensor software providers. The result is the Sensor Hub Solution software suite, which can be used in conjunction with Atmel's development tools suitable for its Cortex-based processors. Renesas offers the RX Sensor Fusion kit. It comprises an RX62N RDK micro-controller evaluation board, a Gyro board, Sensor Fusion demo, and GUI code as well as application notes. The kit is designated for position sensing applications.

In some sensor fusion applications, FPGAs (field programmable gate array) are used. Therefore, Altera has developed special functions for sensor fusion devices. This includes camera, radar, and ultrasonic functions. System-on-Chips (SoC) featuring sensor fusion will grow with an annual rate of 60 percent, predicted Semico Research. This growth will result in about 2,5 billion units in the year 2016, mainly used in smartphones, tablets, and digital cameras.

Texas Instruments has published an application note [6] for a 9-axis sensor fusion using the direction cosine matrix (DCM) algorithm on the MSP430F5xx processor family. The report explains the implementation of an AHRS, which is based on magnetometers. The calibrated sensor values are fed to the DCM algorithm in order to calculate the roll, pitch, and yaw values (Euler angles). Using a CAN connectable micro-controller, these values can be sent to other ECUs.

Software support means mainly tools. Baselabs provides a hybrid approach for ADAS data fusion algorithm

development. The hybrid development offers a way to combine the advantages of model-based and code-based solutions. Baselabs tools support data logging and handling as well as the development of algorithms for data fusion. They are an alternative to Simulink (model-based) or to Matlab (code-based). Baselabs tools need less set-ups, claims the provider.

## Integrating smartphones

Besides chipmakers, other parties are also developing sensor fusion software. Some OEMs and chipmakers are co-operating with universities to develop such software suites. There are also new sensor fusion applications for passenger cars. The University of Paderborn has developed a smartphone-based navigation system using speed information from the CAN in-vehicle networks. The researcher connected an Android phone via a Bluetooth-to-CAN gateway to the in-vehicle network. The sensor fusion was carried out by an error-state Kalman filter, whose complexity was reduced to achieve real-time operation. Several carmakers (Daimler, Ford, and General Motors) have considered integrating smartphones into the car's electronic control system. General Motors has proposed the Autolog programming framework [1]. Experimental results have shown that the latency could be reduced by the factor four to seven, relative to a not optimized solution. Autolog uses Datalog to express sensor fusion, but incorporates some optimization methods, which minimizes bandwidth usage and latency problems.

## Security needs to be considered

Security is an issue in mission-critical applications. Last year, the University of Pennsylvania presented its attack-resilient sensor fusion concept. The researchers studied a shared bus, such as CAN, on which messages are broadcasted. They investigated the effects of communication schedules on sensor fusion performance. In addition to the simulation, the researchers used a Land Shark robot with four sensors. This robot is commonly used in hostile environments to save injured people or carry cargo. It has four

## Bayes' theorem

This theorem deals with the relation of a current probability to the prior probability. The interpretation of Bayes' theorem varies. In the Bayesian interpretation, the probability is based on the degree of belief. The other interpretation relies on the proportion of outcomes. The Bayesian approach has been used for example for a multi-sensor pedestrian detection system [A]. In the simplest case, a Bayesian network is specified by an expert and is then used to perform inference. In more complex cases, it is not possible to define a model. In this case the network structure and the parameters of the local distributions must be learned from the data.

[A] [L. Ngako Pangop and others: A Bayesian multi-sensor fusion approach integrating correlated data applied to a real-time pedestrian detection system. IROS workshop 2008.](#)

sensors that estimate its speed – GPS, two encoders, and a camera. “We assumed that at most one sensor can be attacked at any given point of time. In addition, while it is true that some sensors are easier to spoof than others, we assumed that any sensor can be attacked in this scenario; if it is known which sensor is being attacked then any schedule that places that sensor first would result in a smaller fusion interval,” explained the researchers. They proposed a communication schedule, namely the Ascending schedule, which aims to minimize the attacker’s capabilities by either providing little information (sending at the beginning of the schedule) or little power (larger intervals). Of course, more research is needed on how to secure sensor fusion. The reported study assumed uncompromised sensors that always provide correct measurements. An extension of random faults in addition to attacks has to be the next step.

### Applications are not limited to cars

Sensor fusion is not limited to mobile computing equipment such as smartphones and tablets or road vehicles. Application opportunities can also be found in mobile machines including precision farming applications and mobile robots. One example is the fusion of sensor data for moving robots: gear and force data are fused to Cartesian leg force data, which is combined with positioning information, resulting in a total force vector.

The California Polytechnic State University has developed a sensor fusion application for a low-cost truck

collision avoidance system. The focus of this sensing system is to prevent rear impacts and sideswipe crashes. A system that provides coverage for these crash modes requires the use of both short range and long range sensors. Ultrasonic and magnetic sensors provide lateral blind-spot detection, while a radar sensor monitors the rear. The following sensors were selected: the HMC2003 three-axis magneto-resistive sensor by Honeywell, the LV-MaxSonar.EZ ultrasonic sensor by Maxbotix, and a radar sensor with CAN interface. A mathematical model was created to understand the behavior of the magnetic signal as a vehicle passes the sensor. This model includes the effects of magnetic field strength, vehicle dimensions, and the number of acting dipoles. The model can be used to set numeric values for various object types. A Bayesian recursive model was created to convey the likelihood of a vehicle being present in the lateral blind zones of a large truck. The algorithm helps to integrate multiple sensors. By knowing the advantages and limitations of each sensor, the algorithm can help alleviate false positives that may arise with the use of standalone sensors.

In complex applications, sensor data are available in different CAN-based networks which are not synchronized. One of the options is to use the TTCAN protocol as defined in ISO 11898-4. Combined with the CAN FD data link layer protocol, this approach provides sufficient bandwidth and may avoid patent infringements (e.g. with US8504864), if all networks use the very same global time reference.

# LIN & CAN Bus simulation for test and production

LIN protocol >= 2.0 only:

Produkt-ID des Herstellers:

Funktion:

Variante:

Antwortfehler:

P2 min [ms]:

ST min [ms]:

N\_As Timeout [ms]:

N\_Cr Timeout [ms]:

I/O Digital

## CAN products ready-to-go

In particular for low-volume applications, off-the-shelf sensor fusion products are needed. The first companies have developed such products. Smart Microwave Sensors offers the Bumber-08xx electronic control unit for experimental vehicles. It collects data from different sensors (range, angle/position, radial speed, reflectivity level, etc.) and fuses them. Alternatively a PC with CAN connectivity can be used for data fusion. The Drive-Recorder software supports sensor fusion.

Low-cost is a demand. The Swiss U-Blox company has developed a sensor fusion dead reckoning system in cooperation with ETH university in Zurich (Switzerland). The UBX-M8030-Kx-DR chip includes a sensor fusion engine that blends data from satellites with wheel tick, gyroscope, and accelerometer data from the CAN in-vehicle network. This chipset is able to accurately track a vehicle's position during the drive of a 5-story park garage with multiple 360-degree turns. The car used in this test was an Opel Astra. The system comprises a low-cost single-frequency GNSS receiver and a MEMS gyroscope with wheel tick sensor. On the basis of tick and gyroscope measurements from a single wheel, the vehicle speed and heading rate can be calculated. In order to achieve optimal dead reckoning performance, the GNSS and sensor measurements are combined using a tightly-coupled extended Kalman filter allowing for a continuous and automatic calibration of unknown sensor parameters, such as bias and scaling factor of the gyroscope and the scaling factor for the wheel ticks representing the wheel's radius. Since the temperature dependent drift of the gyroscope bias during GNSS outages can degrade the dead reckoning performance significantly, temperature and gyroscope bias are simultaneously measured while the vehicle stands still and the Temperature Compensation Table (TCT) is updated continuously. Future developments of MEMS gyroscopes with improved measurement stability and sensitivity will broaden the application area further.

Life Performance Research (Japan) has developed the LPMS Motion Sensor, which consists of a miniature IMU and an AHRS. It uses a 3-axis accelerometer, gyro and magneto sensors, and an integral Kalman filter. The product supports update rates of up to 500 Hz and comes optionally with a CAN interface. It can be used for motion capturing and vehicle dynamic applications. For the CAN interface, which is able to run at 1 Mbit/s, optional CANopen support is available. However, there is no standardized CANopen framework or profile available for devices featuring sensor fusion capabilities.

Quanergy Systems (USA) has developed an ADAS system using Lidar (Light Detection and Ranging) laser sensors. They are linked to the Tegra 1 processor via Ethernet. The processor by NVIDIA is the heart of the data fusion engine, which is connected to the CAN in-vehicle networks. Via CAN the unit receives velocity, acceleration, and brake pedal position values as well as other data available on the OBDII on-board diagnostic interface. The resulting data shown on the head-up display or the vibration commands for the steering wheel and the seat are

communicated via CAN as well as other auditory cues (beeps and vocal commands).

Peak (Germany) offers the PCAN-GPS module, a programmable sensor unit for position and orientation determination. It features a satellite receiver, a magnetic field sensor, an accelerometer, and a gyroscope. The sampled data can be transmitted via CAN and logged on the internal memory card. The data is processed by a NXP LPC4000 micro-controller. Using the supplied library and the Yagarto GNU ARM tool-chain (contains the GNU Compiler Collection GCC for C and C++), application firmware can be created and then transferred to the module via CAN. This includes options to manipulate, evaluate, filter, and route the data. PCAN-GPS is provided with a demo firmware that transmits the raw data of the sensors periodically via CAN. The source code of the demo firmware as well as further programming examples are part of the delivery.

*Holger Zeltwanger*

## Literature

- [1] [Yurong Jiang and others: Flexible and efficient sensor fusion for automotive apps.](#)
- [2] [Christian Lundquist: Sensor fusion for automotive applications. Dissertation 1409, Linköping University, 2011.](#)
- [3] [Ragne Emardson and others: Measurement uncertainty in sensor fusion through non linear Kalman filtering. SP Swedish Technical Research Insitute. Undated.](#)
- [4] [Mark Tucker and others: Real-time embedded sensor fusion for driver assistance. IEEE Conference on intelligent transportation systems, Vienna 2005.](#)
- [5] [James Crowley and Yves Demazeau: Principles and techniques for sensor data fusion. Grenoble, undated.](#)
- [6] [Erick Macias and others: Nine-axis sensor fusion using the direction cosine matrix algorithm on the MSP430F5xx family](#)
- [7] [A. Somieski and others: Low-cost sensor fusion dead reckoning using a single-frequency GNSS receiver combined with gyroscope and wheel tick measurements. 23rd International Technical Meeting of the Satellite Division of the Instute of Navigation, Portland 2010.](#)

# CAN FOR EXTREME ENVIRONMENTS

CANopen Coupler D-Sub /XTR, 750-338/040-000

# CANopen®

# XTR



750-338/040-000



750-8204



750-837



750-838/040-000



750-337



750-338



750-347



750-348



767-1501



767-658 (CAN)

## The WAGO-I/O-SYSTEM 750 XTR – TAKING IT TO THE EXTREME

- eXTReme temperature ... from -40°C to +70°C
- eXTReme vibration ... up to 5g acceleration
- eXTReme isolation ... up to 5 kV impulse voltage
- eXTReme dimensions ... as compact as 750 Series standard

[www.wago.com](http://www.wago.com)

**WE  
INNOVATE!**

**WAGO®**

# Digital transmission in pressure sensors

*When accurate values are required in an application, digital sensors are superior to analog instruments. Particularly in automotive engine test benches, accurate pressure measurements are a must.*

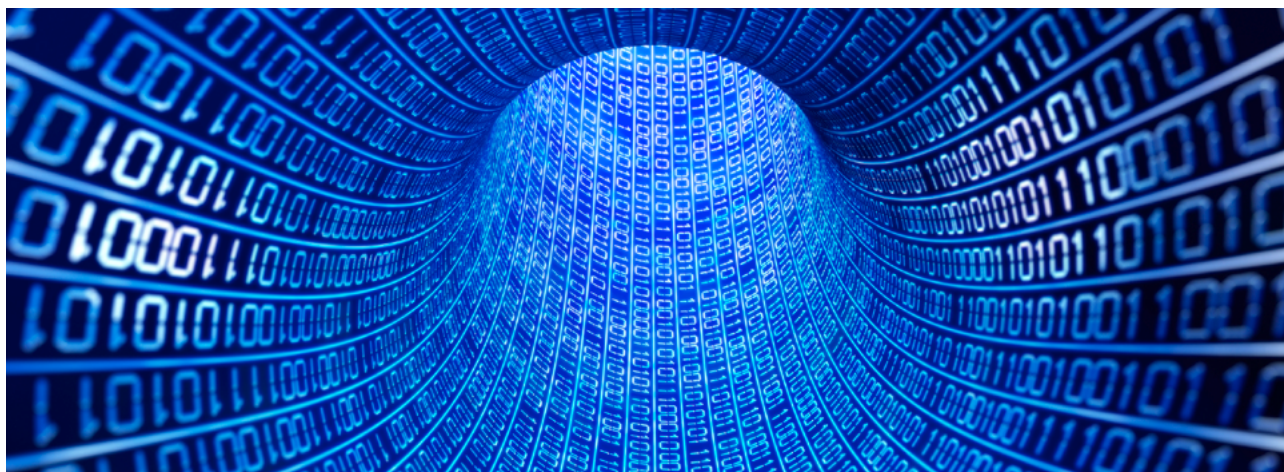

We take a look at the basic design of both analog and digital sensor measuring chains, and also typical error influences. The differences in the wiring and signal evaluation lead to error model calculations that are clearly different from each other. Thus in our example, with lower investment costs, a digital measuring chain can achieve an overall accuracy of 0,1 % while also being more resistant to external interference by design.

Whenever accurate measured values are required in an application, the advantages of digital sensors, compared to analog instruments, become obvious. When talking about digital sensors, we mean sensors with an integrated analog-to-digital conversion, which uses a digital interface to transmit the measured value (e.g. CANopen or USB) with the pressure value transmitted as a numeric value. An analog sensor, however, has no built-in analog-to-digital conversion and transmits its signal as an analog current or voltage signal, e.g. 4 V mA to 20 mA, or 0 V to 10 V.

Therefore, in applications where high accuracy is required, for example in test stands for propulsion technology, it is advisable to use digital sensors. This avoids further sources of error that exist in analog instruments, over and above the signal conditioning, as a result of the analog signal transmission. Figure 1 shows the schematic design of a typical analog pressure sensor. By the deformation of a diaphragm under a pressure load, a resistance change occurs in the resistance bridge fixed to the diaphragm. This change in resistance is converted into an electrical signal, amplified and transformed into a standard signal. The compensation of the sensor-specific errors (zero error, span error, non-linearity) is also made through analog circuit technology, for example, resistance networks. With digital sensors, however, the electrical signal of the resistance bridge is directly

converted into a digital value and the subsequent compensation is instead made mathematically in a microprocessor (see Figure 1). Here, depending on the required accuracy, non-linear errors of any order can be compensated and accuracies up to 0,05 % can be achieved at low costs. By using a  $\mu\text{C}$ , an active temperature compensation is also possible, eliminating any temperature error within a defined temperature range. This compensated digital signal now exists in the pressure transmitter as a numerical value and then can be output via any digital protocol (e.g. USB, CANopen, etc.). During the onward transmission of this digital pressure signal, it is now immune to interferences which might cause a further deterioration in the accuracy.

If we compare the complete analog measuring chain with its digital counterpart, the advantages of digital sensors become even clearer. Figure 2 shows the schematic structure and at which point external interferences, such as EMC or temperature, introduce additional errors.

Initially, the analog front end of both sensor principles is adversely affected by environmental influences such as temperature fluctuations, EMC, etc. However, in the case of the digital pressure transmitter, the pressure signal is no longer influenced by external effects after the AD conversion. In the case of the analog signal chain, even the internal compensation is subject to possible temperature effects due to passive components. The output driver that generates the standardized output signal (e.g. 4 mA to 20 mA or 0 V to 10 V) is also constrained by a variety of external influences (cable length, input impedance of the signal evaluation, temperature, EMC, etc.). Anyone who has tried to evaluate an analog sensor signal with high precision will also know the problem of signal noise. Even in the unpresurized state, the evaluated signal is not fixed at 4 mA but



fluctuating within a particular range, e.g. 3985 mA to 4007 mA. This is mainly due to environmental influences which the signal cable picks up, acting as an "antenna".

For further processing, this analog signal value must be digitized, if only for visualization on a display or as a control variable for a controller. I/O channels of programmable logic controllers (PLCs) or external A/D modules can be used for this. These components are also subjected to environmental factors that have a negative impact on the accuracy of the measured value acquisition. Thus, these A/D evaluation modules also have a specified accuracy, which is the best to which they can determine an analog signal. This means that the inaccuracy of the sensor itself is further added to by a deterioration in accuracy at the A/D module. This error through the A/D conversion, in turn, is also temperature dependent and, at the limits of the operating temperature range, will become even larger.

In digital signal transmission, the overall accuracy of the measuring chain is influenced solely by the inaccuracy of the sensor. Following the A/D conversion within the sensor, the pressure is available as a numerical value. This can be adapted through a microprocessor to any digital bus signal (CANopen, USB, Profibus). This adaptation has no influence on the accuracy specification, nor is the transmission of the digital signal subject to any influences that would degrade the accuracy. So, with the example of CANopen as the transmission protocol, cable lengths of 1000 m are possible without any effect on the accuracy of the pressure signal. Moreover, no additional error occurs

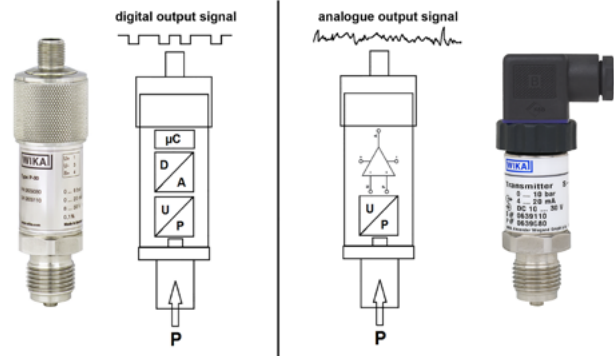
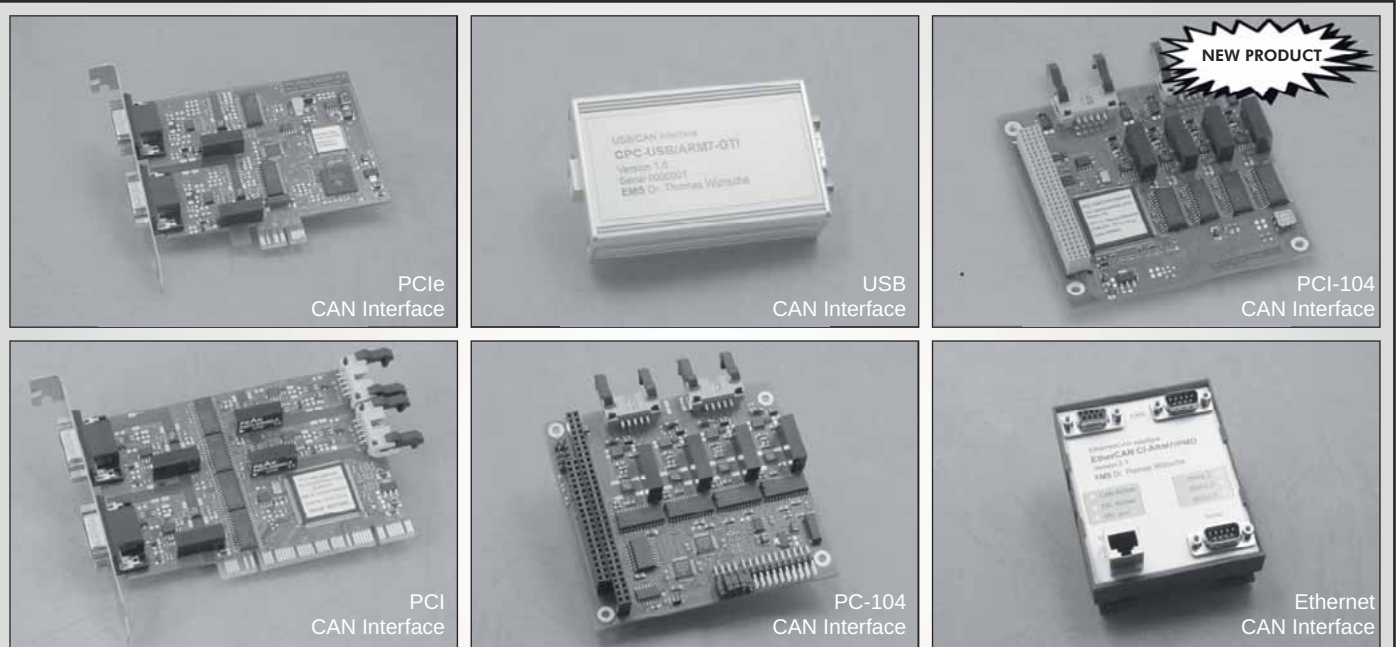

Figure 1: Design of a digital pressure transmitter vs. an analog pressure transmitter

at the signal evaluation end. There, one finds a digital bus master, which reads the digital values from the bus and forwards them to the appropriate software/process control element. This all takes place with a digital numerical value, unaffected by any environmental influences.

For the sake of completeness, it should be mentioned that strong EMC interferences can also affect digital bus signals. If a pulse-shaped interference is superimposed, a "0" could arrive in the master as a "1". However, this again shows the advantage of using microprocessors that can detect and correct these errors with their built-in "intelligence".

During transmission, algorithms built into the sensor and the PLC ensure that transmission errors are detected. For this, checksums are calculated from the measured >



## CAN Interfaces for Your Requirements

- Economical solutions for series applications
- Optimized for industrial applications
- Solutions for stationary and mobile use
- Software support for bus-analysis, measurement and control

[www.ems-wuensche.com](http://www.ems-wuensche.com)

**EMS** Sonnenhang 3  
D-85304 Illmünster  
Tel. +49-8441-490260  
Thomas Wünsche Fax. +49-8441-81860

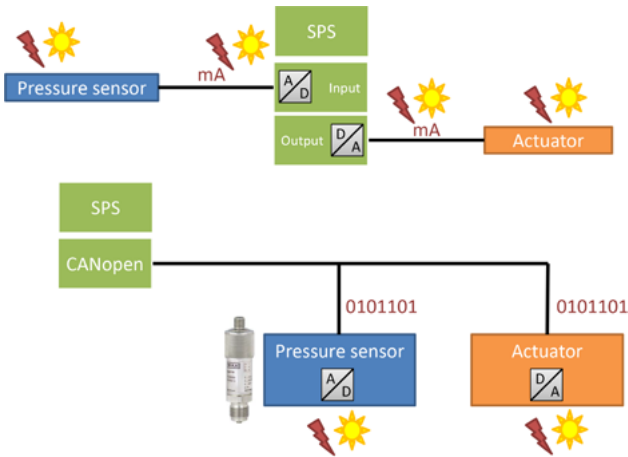

Figure 2: Analog and digital measuring chains in comparison

values by using cyclic redundancy checks (CRC) and for any discrepancies the measured value will be discarded and requested again. To some extent, it is also possible to calculate the correct measured value from the transmitted checksum and thus the transmission errors generated can be corrected. This then avoids re-transmissions and the associated loss of time.

In the digital measuring chain design, it is not just the susceptibility to error that is reduced, but also the amount of wiring. Each sensor and actuator no longer needs its own signal line, but rather many nodes can be connected via a single, branched line. In the case of CANopen, up to 127 nodes can be connected to a PLC input card via a single cable with three lines (CAN\_H, CAN\_L, GND).

Many manufacturers now operate on the basis of identical component strategies when configuring digital sensors – the compensated pressure value is then ready to be transformed back to an analog standard signal through a D/A conversion. In the context of the comparison of analog and digital sensor technology, this is almost the worst strategy. Here, the digital, compensated, “clean” sensor signal is converted back into an analog value that can be distorted by the effects of temperature, quantization errors, and other disturbances. Thus it makes sense, once the effort of processing the sensor signal into a digital one was already made, that it should be transmitted digitally to the PLC, eliminating further sources of error.

After comparing the basic construction of the measuring chains, we should now also look at the advantages using a calculated example of an accuracy assessment. Pressure sensors are available in both digital and analog versions at reasonable prices with accuracies of up to 0,1 %. This accuracy should be used as a baseline in both cases.

In the example of the analog signal chain, an error of about 0,1 % can occur along the path of transmission. High contact resistance at the connection points in the case of 0-V to 10-V signals or the superposition of electromagnetic interferences (e.g. in the vicinity of pumps or motors or other potent sources of interference) can be the cause of these effects along the transmission line.

Low-cost analog input modules offer resolutions in the range of 10 bit to 14 bit and possess a basic accuracy of 1 %. Of course, this error is then added to the error of the sensor. With these specified accuracies, however, only the accuracy at the reference conditions is covered – if one moves outside of these reference conditions, further errors are accrued. Typical values here are in the range of an additional 1 % temperature error over the entire temperature range.

Even analog input modules of the highest quality, with up to 24-bit resolution, still have inaccuracies of 0,1 %. And still, with these modules, additional temperature errors must be taken into account – although these are very low, they can still be in the range of 10 ppm/°C. For a module that can be used in the range of -40 °C to 125 °C, this would constitute an additional error of 0,165 % over the temperature range.

Purely mathematically, the two cases are represented as follows:

- ◆ “Low-cost” analog input module:  
 $0,1 \% \text{ (pressure transmitter)} + 0,1 \% \text{ (transmission path)} + 1 \% \text{ (analog input module)} + 1 \% \text{ (analog input module temperature error)} = 2,2 \%$
- ◆ “High-quality” analog input module:  
 $0,1 \% \text{ (pressure transmitter)} + 0,1 \% \text{ (transmission path)} + 0,1 \% \text{ (analog input module)} + 0,165 \% \text{ (analog input module temperature error)} = 0,465 \%$

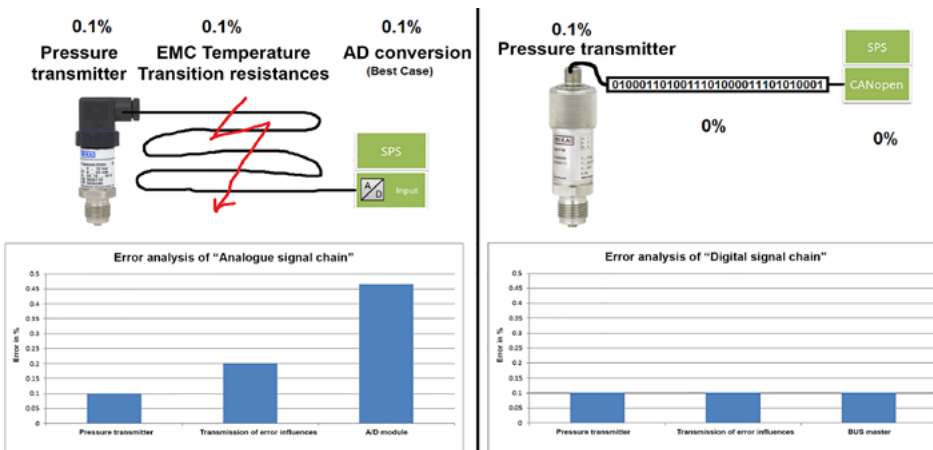

Figure 3: Error analysis of the measuring chain in comparison

The estimation of the digital signal chain, however, turns out to be significantly simpler. Here, the basic accuracy of the pressure transmitter stands (0,1 % in our example), and there are no additional error influences in the onward signal path, so the measured value, which is used in the evaluation process, actually comes with an accuracy of 0,1 %.

Digital systems also offer benefits on the cost side. The additional costs

for sensors with digital interfaces have decreased in recent years. In the example of the pressure transmitter, one supplier of complete pressure transmitter families lets customers choose between analog and digital output signals at no extra charge. The cables required to transmit digital signals are quite expensive when compared to their analog counterpart, though in the case of a bus system, only one line is required. An analog signal transmission cable is required per measurement point, so in total, the wiring for the digital system can be more cost-effective.

Table 1: Comparison of a digital and an analog chain

Digital signal chain		Analog signal chain	
Simple cabling, 1 cable for complete bus	+	-	Complicated cabling, 1 cable per measuring point
No deterioration in accuracy over the transmission path	+	-	Accuracy deterioration effects on transmission
No deterioration in accuracy with the signal evaluation	+	-	Additional measuring errors through A/D module
Low cost for bus master	+	-	High cost for A/D module
Fault diagnosis	+	-	
Parameterization of the measuring points over the bus			

However, the lion's share of the cost is in the signal evaluation. High-quality A/D modules with, for example, 8 analog inputs and 16-bit resolution, come at a price of around €2000. This causes an additional cost of €250 per measurement point. Bus masters for common fieldbuses are in the range €200 to €500, irrespective of the number of required measuring points. In most automation systems, one or more fieldbuses are already in use, so to some extent the cost of the sensor evaluation is already accounted for, since these can be attached to the existing bus.

In summary, digital measuring chains exhibit their strength in applications with multiple measuring points where a secure and accurate transmission of measured values is needed. Particularly in the example of engine test benches that run for considerable periods in an environment where elevated temperatures and also strong EMC interference prevail, using a fully digital measuring chain is recommended. ◀

Authors



Maurice Bildstein, Stefan Heusel  
 Wika Alexander Wiegand SE & Co. KG  
[www.wika.com](http://www.wika.com)



CAN/CAN Gateway

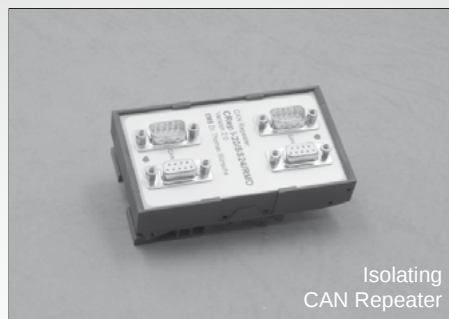

Isolating CAN Repeater

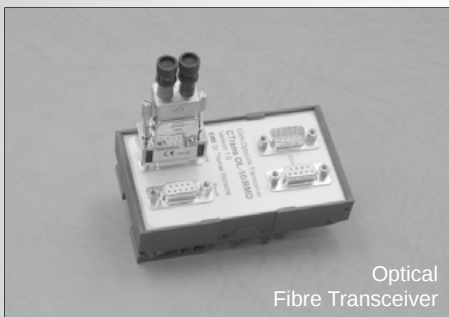

Optical Fibre Transceiver

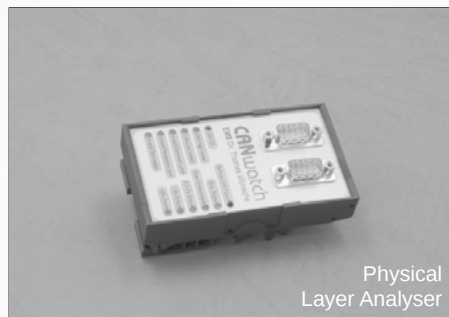

Physical Layer Analyser



Ethernet/CAN Gateway

**EtherCAN CI-ARM9/RMD**

CAN/Ethernet Gateway  
 embedded Linux Kernel 3.5.0  
 ARM9 CPU / 454MHz  
 2GByte EMMC Flash  
 128 MByte RAM

# CAN Network Technology

Successfully applied in

- Machine automation
- Building automation
- Transportation systems
- Telecommunication systems

[www.ems-wuensche.com](http://www.ems-wuensche.com)

**EMS** Sonnenhang 3  
 D-85304 Ilmmünster  
 Tel. +49-8441-490260  
 Thomas Wünsche Fax. +49-8441-81860

# Four CAN networks for electrical racing car

The Formula Student in Hockenheim gives students the chance to race against other student – in a car they built themselves. The team from Munich has high hopes for this year with their electrical racing car.

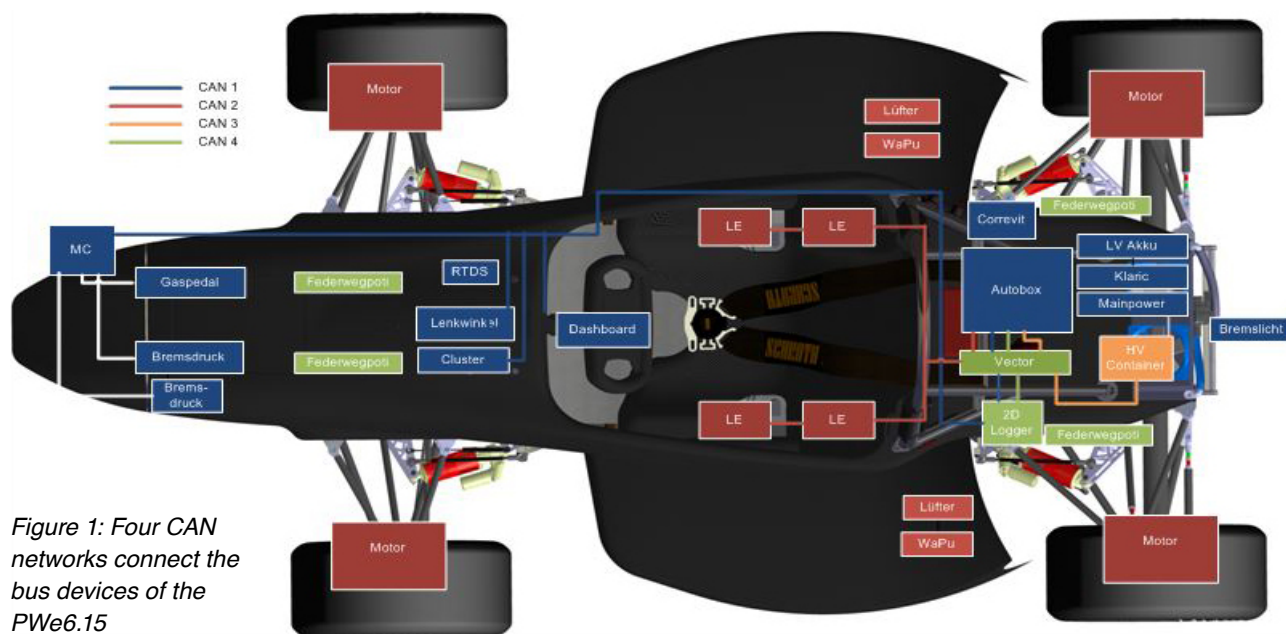

Figure 1: Four CAN networks connect the bus devices of the PWe6.15

The Munich Motorsport team of the University of Applied Sciences Munich was founded in 2005 and has been participating in the Formula Student events since 2006. Our team's aim is to apply theoretical knowledge from lectures to the construction of a racing car. Currently the team has about 70 members from various faculties. Our goal is to build a racing car, mainly for the Formula Student Germany Event in Hockenheim.

With our electrical car, the PWe5.14, the team scored a 4<sup>th</sup> place among 40 other teams at last year's Formula Student. In the category Cost, the car even achieved a 1<sup>st</sup> place. Next year, we will face a new challenge for the electrical vehicle: because we think we tapped the full performance potential of a rear-mounted drive with the PWe5.14, we want to increase the PWe6.15's efficiency with a four-wheel-drive system.

Some main characteristics of our PWe6.15 are for example a redesigned Monocoque, which forms the primary structure of the car, and a powertrain concept comprising four electric engines with planetary gears that accelerate the hub. For the data transfer between the technical systems in the PWe6.15, we use CAN technology.

There were three main reasons why we decided to use a bus technology: usability, flexibility, and simplicity. With the help of a bus system we were able to reduce the amount of cables, which resulted in a more condensed loom, an increased maintainability and a clear arrangement. Moreover, in a racing series without weight limitations, every team tries to build the lightest car possible, which at the

same time should have the best track performance. Therefore, weight is a key point in designing and constructing every single part of the vehicle. Consequently, saving weight was one of the main goals during considerations of the bus structure. With a lot of analog sensors integrated in the car, the distances the signals have to travel should be short in order to avoid signal interferences and non-traceability. As a result, we digitalize the signals as soon as possible with the help of micro-controllers and put them on the bus.

A CAN network was chosen since evaluation results showed that a Flexray network would be too complex for our use case. Flexray networks are commonly used for real-time applications, for example driver assistance systems. LIN networks were ruled out, because of the low data rate of 20 kbit/s. We require a rate of about 500 kbit/s. Furthermore, LIN is a single-wire network with lower reliability and robustness.

In our car, we use four CAN networks with a rate of 500 kbit/s. CAN network number one is the so called Drive-CAN, on which we transmit relevant sensor data and signals coming from and going to the dashboard. The second CAN network is reserved for information received from electric engines, the inverter, and power electronics, which can also be controlled by means of the bus communication. The third one is used for receiving data from the battery management system. Thereby, we obtain an overview of the battery cells' status and are able to observe running processes. The last network is required for data of the Correvit and ride height sensor received by suspension and chassis elements. ▶

Table 1: Busload calculation for CAN network #1  
(bit-rate: 500 kbit/s using the base frame format)

CAN-IDs	Description	Data field length [bit]	Refresh rate [Hz]	Number of bits [1/s]
101 <sub>h</sub>	Steering angle, torque encoder, brake pressure	64	200	25400
400 <sub>h</sub>	Dashboard (buttons/rotary switches)	64	10	790
603 <sub>h</sub>	Roll, pitch, yaw angles	64	100	12700
604 <sub>h</sub>	Cluster info (temperature, supply voltage, body speed, time)	64	10	1270
605 <sub>h</sub>	x, y, z acceleration	64	100	12700
606 <sub>h</sub>	Roll, pitch, yaw rate	64	100	12700
700 <sub>h</sub>	Dashboard (status LEDs, RTDS)	16	10	700
n.a.	Correvit sensor by Kistler	64	250	31750
n.a.	Total data	n.a.	n.a.	98010

The CAN network consists of two drilled wires, which are connected in a linear bus structure. In order to put analog signals on the bus, we use Atmel's Atmega64M1 micro-controller fixed on self-developed boards, which are placed next to the sensors. The utilized micro-controller, which digitalizes the analog signals, has eleven ADCs with a resolution of 10 bit. These micro-controllers are for example installed in the dashboard to control buttons and LEDs and one at the rear and the front for acceleration, brake pressure, potentiometers of the springs, gearbox, and tire temperature sensors.

The ID allocation on the CAN network is ordered by priority, giving the highest priority to driving relevant and safety signals. The most important ones have the lowest IDs as higher IDs are lost in case of an overloaded bus system. For example, the torque encoder has the ID 101<sub>h</sub> and a LED in the dashboard has the ID 700<sub>h</sub>. To prevent such issues, we try to keep the busload on a minimum level by adjusting the bit-rate. With a bit-rate of 500 kbit/s we only reach a busload of 19,6 %.

Additionally, we can observe and control the busload with our logger system. The logger records all four CAN networks and measures the busload, which we can review in the log files afterwards. For telemetry applications and live surveillance, we use an extra PCAN analyzer. ◀



#### Authors

Felix Breuer, Stefan Heise  
Munich Motorsport  
[www.munichmotorsport.de](http://www.munichmotorsport.de)

*digsy*<sup>®</sup> fusion

– the safety controller

advanced + safe

PL d Cat. 3 according to EN ISO 13849

powerful + safe

redundant 32 bit CPU and FPU

flexible + safe

safe I/O extensions

adaptable + safe

safe and standard program

w/o feedback



[www.intercontrol.de](http://www.intercontrol.de)  
[info@intercontrol.de](mailto:info@intercontrol.de)  
Tel. +49 911 9522-851



# CAN FD simulation in real-time systems

*Migration from Classical CAN to CAN FD affects both the hardware and the application software. Real-time simulations must support the steps necessary for migration.*



Figure 1: FPGA-based CAN FD module for use in RCP and HiL systems

Over the next few years, many ECU networks will migrate from Classical CAN to CAN FD. This new type of network increases the payload length and offers a higher bandwidth, while still providing the advantages of CAN, namely flexibility and affordability. The basic mechanisms of arbitration, message acknowledgement, and frame setup remain unchanged. It is therefore possible to further develop existing topologies, and developers can continue to use their working methods and accumulated know-how. Nevertheless, changing the network also poses a challenge because it affects both the hardware and the application software. The real-time simulation must support the steps necessary for migration, so the complete ECU can be validated.

## Migrating from Classical CAN to CAN FD

The hardware changes required for the migration from Classical CAN to CAN FD are straightforward. The only prerequisite is that the ECU's CAN controllers are prepared for use with CAN FD. One way of migrating is to use CAN FD passive parts that ignore certain CAN FD messages instead of destroying them via the error frame. This change is mainly a hardware change and barely affects the real-time software, but it makes it possible to build mixed networks with

both CAN and CAN FD, in which some network nodes use the new CAN FD frames, while the others exchange Classical CAN frames.

It is also possible to create networks, e.g. private networks, that contain only CAN FD nodes. These extended networks let developers exchange more data between the distributed control algorithms without performing major changes in the topology. The application software can then be migrated to CAN FD. The new capabilities offered by CAN FD depend widely on the application programming interface (COM interfaces or PDU routing). To validate the application with its algorithms and to test the ECU, the CAN communication has to be validated in real time.

## Simulating CAN FD in real time

Restbus simulation has established itself as a way of validating the communication behavior and the related functions of one or more ECUs. In restbus simulations, only part of a networked communication system is actually present. Communication with the missing bus nodes is emulated by a test system. The test system must therefore be able to simulate CAN and CAN FD communication, including all network properties. ▶

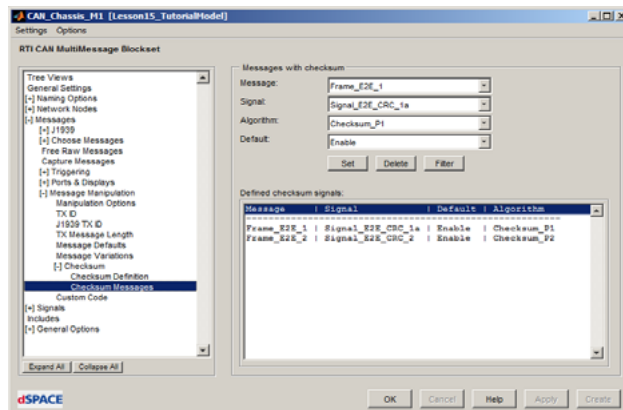
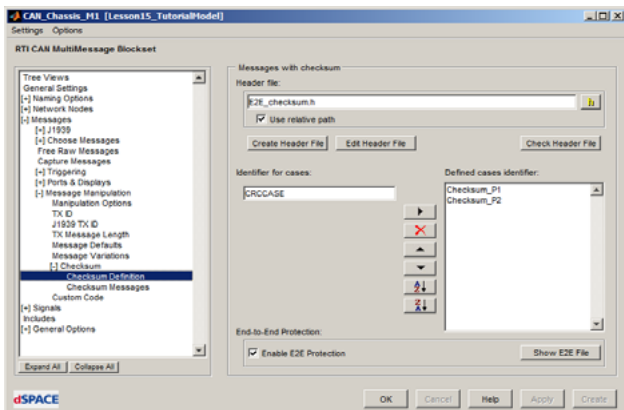

Figure 2: Pre configuration of CRC algorithms with the RTI CAN Multi Message Blockset

Dspace has expanded its product range with new software functions and hardware to include and simulate CAN FD systems. Existing systems are easy to integrate into the new FPGA-based DS4342 CAN FD Interface Module. With this module, CAN FD can be used in the known rapid control prototyping (RCP) systems, such as Micro Auto Box II, and the modular hardware systems for Hardware-in-the-Loop (HiL) simulators. To configure the restbus simulation, the customer can still rely on the tried and tested RTI CAN Multi Message Blockset, which supports both CAN FD hardware and existing Classical CAN hardware. Porting existing configurations to the new CAN FD module is possible. New configurations are based on read-in communication databases, such as Autosar System Templates, Fibex files, or DBC files. The user can configure restbus simulations via a graphical user interface, without manual programming.

The implementation software has functionalities especially for testing communication. Here, users can test not only 'good behavior', such as the functionality with correct input data. They can also test 'bad behavior' by inserting failures into the communication. The data to be sent can be created statically or synthetically by using existing algorithms, or it can come from the real-time model through a connection to Matlab/Simulink.

The RTI CAN Multi Message Blockset's functions are subdivided into message-level and signal-level functions. At message level, the test functions control the transmission of messages and other actions, including the targeted failure of single messages or even whole ECUs. The tool also covers tests at signal level. There is the mandatory option for transmitting fixed static values, plus an option for transmitting signals from the real-time model. In addition, the user has access to the typical functions for defining contents and manipulating signals. These include functions for the implementation of specific checksums and CRC algorithms, for instance for validating end-to-end protection (E2E).

The RTI CAN Multi Message Blockset lets users define abstract CRC algorithms that can be parameterized with E2E protection data from the communication database. These CRC algorithms are then assigned to the different CAN messages. In this way, developers can reuse CRC algorithms for a large number of different CAN messages or even build a library for CRC algorithms.

Configurations created in this manner also provide dynamic entry points for testing and automating the communication later on. This is done via the central tool Control Desk

Next Generation and its Bus Navigator. The Bus Navigator's tree view is the central access point for handling. It contains the model's CAN communication that was configured with the RTI CAN Multi Message Blockset. In the tree view, layouts that mirror the send and receive configuration of the messages and signals from the real-time model can be generated as needed. These layouts contain, for example, options for the transmission control of the messages, such as an edit field to set the cycle time or a button to send messages sporadically.

To analyze the communication behavior comprehensively, there are functions for communication logging or monitoring with different views, filters, and sorting options.

The extended tool chain proves that CAN FD functionality can be used without causing operating or compatibility problems, because all existing CAN configurations can be used as they are and no additional software license is needed.

CAN FD was created with only a few changes to the well-known mechanisms of Classical CAN. A variable transmission speed and longer payload length ensure flexibility for many applications. Only few changes are necessary to extend existing CAN networks for mixed use. This also applies to the simulation tools whose new hardware and extended software let customers switch from Classical CAN to CAN FD swiftly. ◀



**Authors**

Detlef v. Glahn, Björn Müller  
 Dspace GmbH  
[www.dspace.com](http://www.dspace.com)

# Automated validation of CAN FD networks

With the Invio tool, bus systems like CAN, CAN FD, LIN, and Flexray can be validated automatically to specific evaluation criteria. Furthermore, it supports the simulator environments Saber and System Vision.

The increase of functions in vehicles, which are implemented by electronic components, has a significant influence on the communication in vehicle networks. More and more functionalities demand higher bandwidths, such as customer requirements in the areas of safety, increased comfort, and improved handling, and thus increase the relevance of automotive electronics. High transmission rates pose new challenges to network designers responsible for the implementation of the physical layers, since the dynamic behavior of the system cannot be predicted by manual calculations. On the other hand, measurements have a reduced significance due to their single result that generally reflects the typical behavior – the behavior at the limit, however, remains unknown.

Therefore the simulation can be used to predict physical behavior and to verify the implementation of the physical layer of a network in consideration of variations of the electronic components and the environment, as well as in corner case areas. In addition, developers can use the simulation to analyze network designs to find a robust layout and to investigate the influences and the interoperability of new components and ECU interfaces with the goal to improve the signal quality and to ensure accurate communication. Below, this is illustrated using the example of the validation of CAN FD networks.

## Simulation

Particularly in CAN FD networks, the use of simulations is necessary, since the asymmetry of the signal edges plays an important role due to the possible higher transmission rates during the data phase in relation to the arbitration phase, in comparison to Classical CAN. Environmental conditions, such as high or low temperatures, can addition-

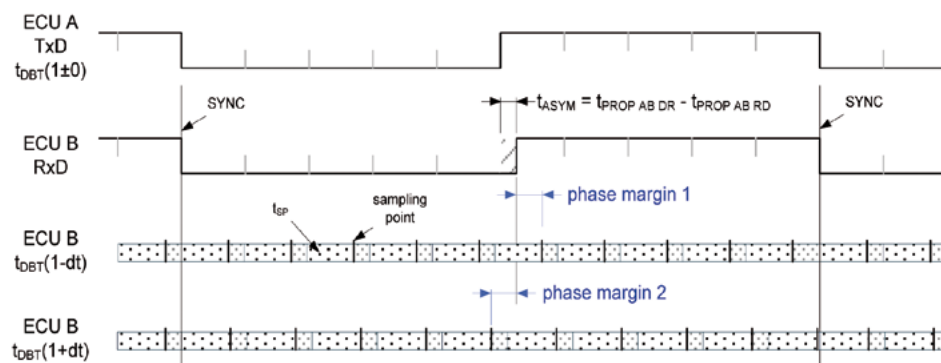

Figure 1: Principle of phase shift of the signal edges before and after the sampling point

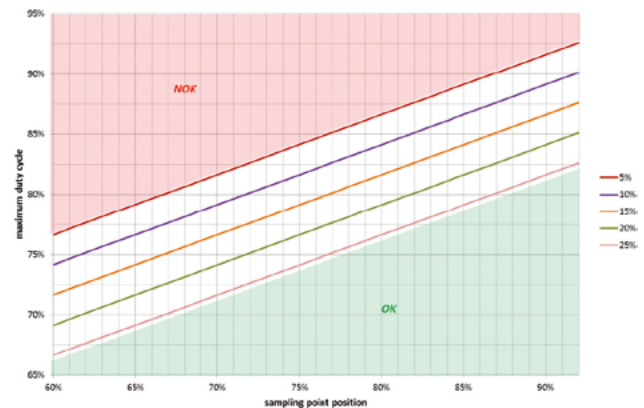

Figure 2: Example of the dependence between the duty cycle limits and the sampling point at different allowed phase shifts

ally intensify negative effects on the asymmetry of the signal edges, which can be easily analyzed via the simulation.

CAN FD and Classical CAN use the very same arbitration method. The same rules and limits for the arbitration phase as in Classical CAN are valid. However, in order to judge the asymmetry of the signal edges, new considerations must be taken into account for the CAN FD data phase. The asymmetries of the measured edges within a CAN FD network essentially determine the choice of the sampling point during the data phase. More information about the physical interpretation of busses of the CAN FD networks can be found in [3], [4], and [5].

In a CAN FD network, the arrangement or integration of control devices or the choice of driver components and transmission lines causes an individual signal characteristic, which has effects on the asymmetry of the signal edges. This illustrates the importance and necessity of

simulating such networks. To study the signal integrity in an early development phase of a vehicle, a simulation as a model-based testing of networks is necessary. This requires appropriate models [1] to create confidence in the results.

The evaluation of vehicle networks using simulations is increasingly established and it can be seen that this trend is growing continuously.



With the need of simulations of CAN FD networks, this trend is further intensified. Although car manufacturers have the necessary expertise when it comes to vehicle networks, there aren't always enough experts or resources available to secure and release the networks at an early stage, whether through measurement, simulation or to analyze improvement measures and to make appropriate recommendations.

The following example of the analysis of a CAN FD network should explain the extent that is necessary for a final review and release. For a simulation of the example CAN FD network with ten control units, all required models must be configured and the networking of the control devices including the stimulus and measurement components must be created, e.g. on code level or via a schematic editor. In addition, the simulator must be configured and the entire model of the CAN FD network, referred to as a test bench, must be simulated.

To investigate the CAN FD network in extreme conditions such as high and low temperatures, the overall test bench of the network must be reconfigured. A variation of the temperature in two steps is assumed for the following considerations. The number of ten nodes in the network results in 100 transmitter-receiver combinations per simulation run. To study the delay times during the arbitration phase as well as the asymmetry during the data phase, four single measurements for every transmitter-receiver combination arise for each dominant-to-recessive and recessive-to-dominant edge.

In summary, 800 single measurements with an assessment of the results are produced, of which, if required, an image with the signal representation must be created. Finally, a test report must be generated. Even with only a few minutes for each measurement, the overall effort shouldn't be underestimated. Hence, if various networking options (e.g. for possible improvements of the signal quality or model variants) as well as different transmission rates during the data phase are to be examined, the amount of analyses multiplies accordingly. Thus, it appears that through the use of an automated implementation of the simulation, the required resources could be reduced dramatically.

### Automation through simulation

This need for an automated validation of bus systems, which allows automating the evaluation of networks

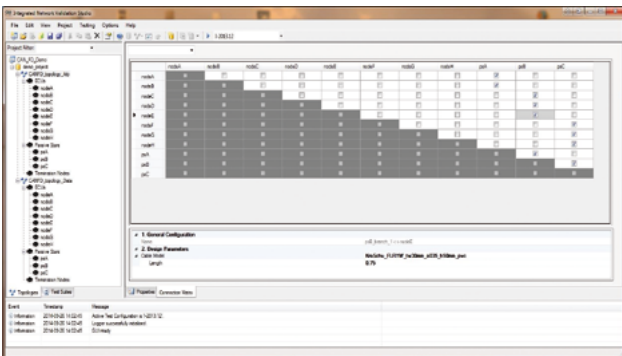

Figure 3: Example of the networking matrix in the "Integrated Network Validation Studio" (Invio)

### References

- [1] Requirement Specification for Transceiver Simulation Models V1.1, ICT/GIFT, 2010
- [2] Automation of model-based signal integrity analyses, Marko Moch, C&S group GmbH, 13th iCC, 2012
- [3] Robustness of a CAN FD Bus System, Dr. Arthur Mutter, Bosch, 14th iCC, 2013
- [4] The Physical Layer in the CAN FD world, Magnus-Maria Hell, Infineon, 14th iCC, 2013
- [5] CAN FD: Impact on System Design, Bernd Elend, NXP, CAN Newsletter 2/2014

through simulations, is covered by the tool "Integrated Network Validation Studio" (Invio) [2]. It allows the validation of CAN, CAN FD, LIN, and Flexray networks according to specific evaluation criteria. The tool supports the simulator environments Synopsys' Saber and Mentor Graphics' System Vision, which are most commonly used in the automotive sector, since the simulation is performed in the hardware description language VHDL-AMS.

The focus of Invio is the comprehensive support of network engineers during the evaluation of network layouts. The automation starts with managing model components that are used conjointly and several times and so-called control unit templates to allow different mountings of model components in the control units. The next step is to define the networks and their variation and to further configure the test cases and setting up the evaluation criteria. With Invio, the network engineer receives support during the development of complete network test benches, their respective simulation and evaluation through measurements, and subsequent calculations up to the result report in the desired file format. ◀

### Authors



Marko Moch  
 C&S Group  
[www.cs-group.de](http://www.cs-group.de)  
 Originally published in Hanser Automotive Special Connected Cars 2014

# Data flow transparency

Rapid developments continue to challenge electronic control units in the automotive industry. This fact must be taken into account by Hardware-in-the-Loop systems.

To solve this challenge for Hardware-in-the-Loop (HiL) systems, Micronova has designed the software feature Bus Tracing for its Novasim simulators. With the help of this feature, all communication buses connected with the system can be monitored and recorded.

Less and less frequently, modern ECUs send or receive required information via dedicated analog or digital lines. Instead, the sensor itself or another ECU puts the information on one or several buses, from where the data can be picked up accordingly. Therefore, the precise knowledge of the data on the buses is essential as this data determines the operating status of the ECU. Depending on the test case, the ECU of the simulator needs to be set to the proper mode of operation at the start of each test. In most cases this is achieved by an appropriate calibration of the bus signals. Only after the testing engineer has set the targeted output mode at the ECU can the errors be entered and the system checked for its error response.

The Bus Tracing feature provides the architecture required to monitor bus data. Based on the existing hardware, data can be collected from different networks, transmitted to the control computer, processed there, and displayed on the user interface. The structure is illustrated in Figure 1.

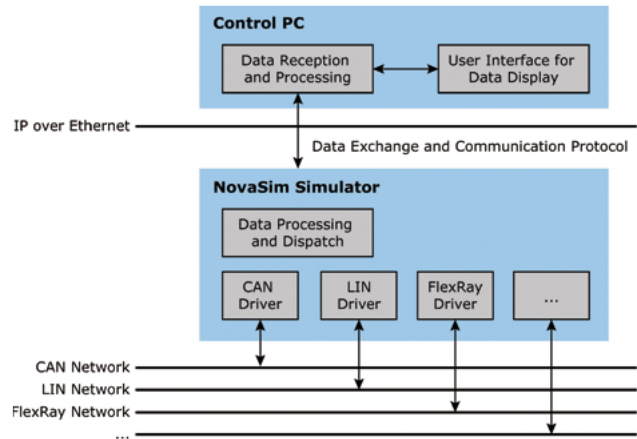

Figure 1: Structure of the Bus Tracing architecture

## Data acquisition

The testing engineer can monitor and record the data of each network used by Novasim on the user interface (see Figure 2). Currently, the solution supports the networks CAN, LIN, and Flexray. The HiL simulator provides the recorded data with a time stamp that is accurate to the millisecond for

HW Timestamp	SW Timestamp	Channel	Direction	Type	ID	Name	Length	Data
8653,9740000	8653,974	CAN1	Rx	Normal	5	MSG_5	100	10 17 D3 55 1A A...
8653,9740000	8653,974	CAN0	Rx	Normal	5	MSG_5	156	AE D8 64 17 B0 B...
8653,9760000	8653,976	CAN0	Rx	Event	6	MSG_6	42	2F 79 44 CF 98 6...
8653,9740000	8653,974	CAN1	Tx	Normal	6	MSG_6	106	E8 AA 21 39 6F 7...
8653,9760000	8653,976	CAN0	Tx	Normal	7	MSG_7	126	1D 92 6C 98 98 F...
8653,9710000	8653,971	CAN1	Rx	Normal	7	MSG_7	129	56 FC 44 B0 D9 8...
8653,9740000	8653,974	CAN1	Tx	Event	8	MSG_8	101	5F B4 D7 36 37 8...
8653,9730000	8653,973	CANU	Tx	Event	8	MSG_8	67	6B UD 1U BD 41 F...
8653,9760000	8653,976	CAN0	Tx	Event	9	MSG_9	47	34 C6 60 14 27 5...
8653,9670000	8653,967	CAN1	Tx	Normal	9	MSG_9	117	B8 CD CF 63 CA 6...

HW Timestamp	SW Timestamp	Name	Data	Channel	ID
8653,9740000	8653,974	MSG_6	E8 AA 21 39 6F 7F A...	CAN1	6
		ID_6Signal_1	57628 (0xE11C)		
8653,9760000	8653,976	MSG_7	1D 92 6C 98 98 FC D...	CAN0	7
		ID_7Signal_1	92 (0x5C)		
		ID_7Signal_2	45574 (0xB206)		
8653,9730000	8653,973	MSG_8	6B 0D 10 BD 41 FD 2...	CAN0	8
		ID_8Signal_1	35359 (0x8A1F)		
		ID_8Signal_2	11767 (0x2DF7)		
		Strom	20,53 A (0xB25C)		
		Spannung	13,9 V (0x956B)		
		Temperatur	24,5 °C (0xFB90)		

Figure 2: User interface of the Novasim Bus Tracing

## Fibex: XML-based file format

The "Fieldbus Exchange Format" (Fibex) is an ASAM-defined and XML-based file format. It contains the information necessary for the description of the communication process on message-oriented communication buses. The information includes the topology, configuration parameters, schedules, frames, and signals as well as their coding on the bit level. It is used for the description of CAN and Flexray communication.

the purpose of a time-related tracing among the records. For some hardware devices, the hardware generates even more accurate time stamps. Each simulator supports up to fifty data channels. The implemented protocol for the communication with the simulator also allows to query the number and type of bus connections installed in the simulator and to display them on the user interface.

## Display and analysis

The traced data is displayed on the user interface along with the identifier, time stamp (software time stamp and hardware time stamp, if any), channel, direction (the Novasim simulator may be sender or receiver), and raw value. In addition, it is possible to display the interpreted data, i.e. the corresponding physical and logical variables. The rule of interpretation is stored in bus description files for each data channel. The format used for the description files of CAN and Flexray is Fibex 3.X, and that of LIN are Intermediate Data Files (IDF).

In order not to lose track in case of high data traffic a filtering system based on messages (ID) and/or buses is included. For the filtering process based on message IDs there are numerous options available including range filters. Furthermore, the user has the advantage of sorting the displayed messages by channel, message ID, and time stamp. The configurations (IP and channel configuration, filter configuration) can be stored and do not need to be re-created in later applications. In order to analyze the recorded communication at a later date, there is an additional option to save the trace in a file (Vector ASCII Logfile format).

Through its compatibility with the HiL simulator, the Bus Tracing feature provides a convenient way to monitor the data traffic on the existing bus systems. By using the existing bus connection no additional hardware is necessary and costs are saved. ◀

## Authors

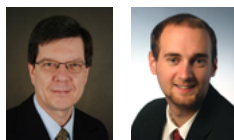

Hermann Naredi-Rainer, Michael Schaffarczyk  
Micronova AG  
[www.micronova.de](http://www.micronova.de)

## USB-to-CAN V2 The good just got better!



## The new generation of IXXAT CAN Interfaces

- For mobile analysis and configuration of CAN systems as well as sophisticated simulation and control
- Up to two CAN interfaces (optional low-speed CAN and LIN)
- USB 2.0 Hi-Speed for minimal latency and high data throughput
- Drivers for Windows and Linux included

The latest generation of IXXAT USB/CAN interfaces from HMS is even more powerful and versatile – at a really low price. The interfaces are available in different versions (compact, professional, automotive).

HMS supports all versions with analysis and configuration tools as well as with drivers, e.g. for CAN, CANopen and SAE J1939.

## NEW

Also available as build-in version (with or without slot bracket) for direct integration into computers or customer devices



HMS Industrial Networks GmbH  
Emmy-Noether-Str. 17 · 76131 Karlsruhe

+49 721 989777-000 · [info@hms-networks.de](mailto:info@hms-networks.de)  
[www.anybus.com](http://www.anybus.com) · [www.ixxat.com](http://www.ixxat.com) · [www.netbiter.com](http://www.netbiter.com)

# CANopen safeguards

*Data transfer over CANopen networks is extremely reliable, but CANopen also offers further safeguards in order to decrease the effect of residual errors further.*

In many applications, complex safety add-ons have been designed on top of existing control systems, which has led to significantly increased complexity and costs. The most significant increase of the performance level can be achieved by replacing all analog signal paths with digital communication [11]: as long as an error can be detected and a control system can perform a reliable reaction, the error cannot cause any harm. When typical failures of systems are analyzed, it is obvious that analog signal paths are the weakest point of any control system [11].

Due to the fact that safety standards cover the entire life cycle of target systems, the design of modern control systems requires not only new technological solutions, but also an updated mindset. In addition to the design of theoretically safe systems, production and service processes must be updated in order to be able to reach the designed performance level (PL) and maintain it throughout the systems' life cycle, as required by the standards [1] [2].

This article explains the application level safeguards briefly listed in [9] in detail and reviews fundamental CANopen services, which decrease the effect of protocol level residual error probability without introducing any additional life cycle costs. Reviews make sense, because most of the presented concepts have already been not only standardized, but implemented in most of the devices on the market and are just waiting to be used.

## Device profiles

Traditionally, each system integrator implements their own low-level controls and management of analog sensors and actuators into PLCs in addition to the application logic. This approach leads to some major drawbacks:

- Proprietary software components are not well specified, because each company uses their own. Using software components only internally gives users a wrong feeling of their "flexibility", leading to unmanaged customizations from project to project. Finally, there are numerous components that are almost similar, leading to a need for tests and the certification of each of them individually [8].

- Often, a proprietary software component is optimized for a single company or even a single department or a single application and for current applications only. Usually, such components are maintained reactively when they are close to becoming obsolete and are thus continuously under development [3].

- The quality assurance of a software component requires a lot of testing and typically some kind of certification(s). If each company tests similar components

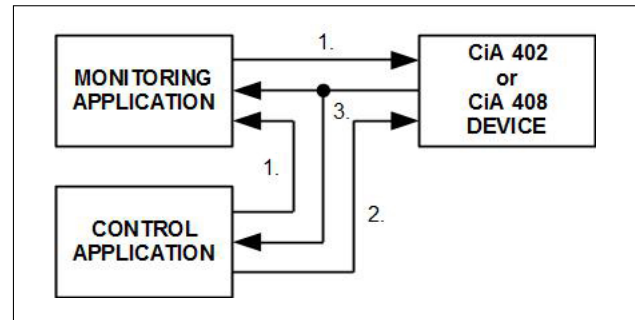

Figure 1: Controlling a CANopen drive with two applications and signals; signal numbers refer to the text

on their own, their work overlaps and they have to test a large number of items [8]. CANopen device profiles in general define a generic architecture of device categories and thus offer a common set of basic I/O, measurement, and drive functions. From a safety point of view, the most important consequence of relying on device profile conformant devices is that each basic function has been designed, implemented, tested, and certified once by the device vendor.

- When a standardized, CANopen-compliant component is used, there is always a globally harmonized system integration interface, enabling the intrinsic re-usability of basic functions without a need for project specific re-testing and -certification.

- Many companies are involved in the development and maintenance of each CANopen device profile. In contrast to proprietary functions, device profiles are more generic and provide a solid basis for various applications, also considering future developments.

- By using standardized functions and components, the device vendor performs unit tests for a single device, the costs of which will be shared by all customers. In the long run, the quality of the functions can be improved faster because each device in each application provides test results to the device vendor.

## NMT state-machine

Analog sensors and actuators start full operation immediately after power-up, without any self-tests and consistency check procedures. In case of a fatal internal failure, there is no service available that informs the rest of the system about the internal initial condition or prevents a faulty operation. The NMT state-machine provides a basic mechanism for safe and manageable behavior [12]. During start-up, each device enters into a pre-operational state, in ►

which the system structure can be checked and optionally correct parameter values can be set. In case of a fatal internal failure, each CANopen device can automatically enter into a defined – preferably stopped – state in order to minimize further failures on the system level.

## Device state-machines

Analog sensors and actuators are stateless, which enables the transmitting or receiving of continuous-time signals only. Thus, analog actuators cannot provide any local safeguards against e.g. cabling failures, which are common and typically lead to wrong behavior. Furthermore, analog actuators cannot enter into the stable error state and safely go back to normal operation when requested.

Some device profiles, e.g. for I/O- [15] and measurement devices [17], have a simple fault mode for outputs, enabling the use of a safe value when set-point signals are not updated. Drive profiles for electric [16] and hydraulic [14] drives have comprehensive device state-machines, which are controlled by an additional signal pair. The state-machine controls the operation of the entire drive. The use of a state-machine decreases the significance of a single communication failure or a communication failure in a single signal. The major benefit of the device state-machine is that error recovery can be accurately controlled and accidental recoveries can be avoided [1].

Another benefit of the device state-machine is that, together with the primary set-point signal, the additional state control and status signals provide dual-channel control for drives [2]. The most common safe state is "stopped", which can be triggered in two ways: First, the main control application can set the set-point value (2) to neutral or the control word to a different value than "device mode active". Second, the monitoring application can force the control word value (1) to a different value than "device mode active".

It has been proved that in an optimum case the main control application sends the set-point(s) directly to the drive (2) in order to minimize the control path latency. The control word (1) may be routed through the monitoring application, because it is used only in the initialization and recovery phases. It is a question of the dependability of the controller devices whether single or dual applications and/or PLCs are needed. The status word and actual values (3) may be used by both applications.

## Actuators to drives

Traditional analog actuators are just actuating components, typically without any internal intelligence and sensing. Additional analog sensors may be installed into analog actuators, but they are not used internally. Thus, such sensors are considered additional sensors, increasing the number of components and amount of cabling.

Modern drives can have internal measurements and control loops. Bi-directional communication interfaces make it easy to access the internal signals. Actual values of drives (S) may be used as a redundant and diverse feedback for controlled axes, enabling the plausibility checking of the primary axis sensor value (P) instead of additional ▶

## Embedded PC solution for DIN rail mounting



## IXXAT Econ 100

With unique multi-protocol support – Supports various fieldbuses and real-time Ethernet via Anybus CompactCom

- Easily programmable via IEC 61131 Soft-PLC
- Integrated analog/digital IOs allow direct connection of sensors and actuators
- High flexibility for best possible adaptation
- Out-of-the-box variants available for EtherCAT and CANopen master
- High performance for demanding real-time applications

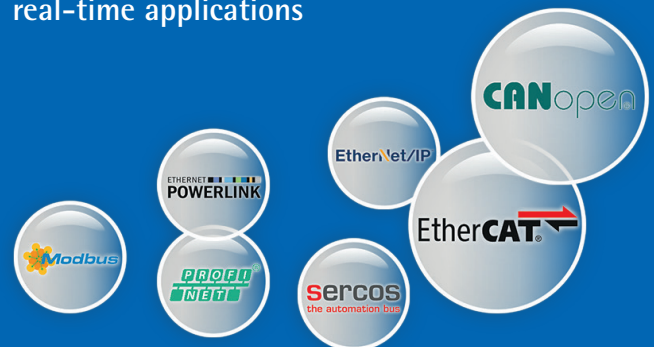

HMS Industrial Networks GmbH  
Emmy-Noether-Str. 17 · 76131 Karlsruhe

+49 721 989777-000 · info@hms-networks.de  
www.anybus.com · www.ixxat.com · www.netbiter.com



sensors [2]. The system complexity is not increased, because neither additional components nor additional cabling are required.

## Membership monitoring

Analog sensors and actuators cannot provide identification. As a consequence, unintentional or unmanaged device installations or changes cannot be detected by the rest of the system, which may lead to degraded performance or even dangerous misbehavior of the entire system. Because CANopen is an integration framework and not only a set of protocol services, it includes comprehensive diagnostic services. Managed network start-up, in conjunction with NMT state machine, provides a simple, efficient, and standardized mechanism for a detailed checking of the system structure identification before full operation during the system power-up [13]. Optional checks may cover the full functionality of each device, including the application software version and device configurations [14]. After the start-up phase, a lightweight on-line membership monitoring provides a continuous monitoring of structural changes. It enables the state monitoring of each device, which can also be used as an information source for the monitoring of received signals [6]. Heartbeat is a point-to-multipoint protocol, enabling system consistency monitoring by an unlimited number of devices.

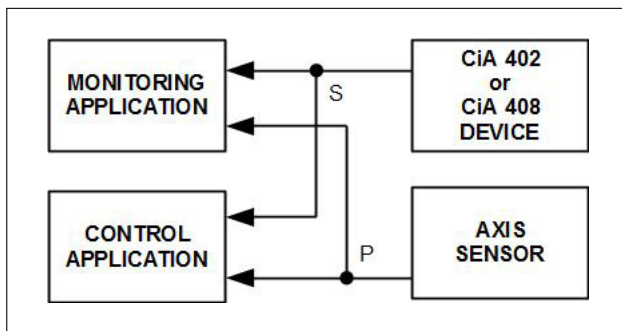

Figure 2: Redundant and diverse feedback may be available from the CANopen drives; signal letters refer to the text

## PDO mapping

Analog signals are sensitive to deviations. Therefore, it is impossible to connect a single analog sensor to multiple input devices without additional active components. Thus, entirely parallel sensor channels are commonly used for monitoring.

PDO mapping is generally understood as a signal routing function only, but it may also be utilized for decreasing the residual error probability of the CANopen communication [9]. In the case of PLCs, there are most probably free objects left in the process image and RPDOs not used for the control application signals. Signals to and from control applications of other PLCs may be mapped from PDOs into the local object dictionary of a PLC, which makes the PLC monitor the structure of those PDOs. This way, more PLCs are able to perform PDO message length checking and increase the spatial coverage of the potential residual errors

passing the CAN layer 2 consistency check. The main constraint of this kind of RPDO monitoring is that only PDOs that are too short can be detected, not ones that are too long.

## Signal validity

In traditional instrumentation, only primary signals are used without redundant services providing validity information of the primary signals or consistency of the system structure. Analog sensors and actuators cannot be identified and thus it is not possible to verify the structure and configuration. Using two analog sensors in parallel may enable the identification of a failure, but not necessarily in which sensor the failure is located. A third one is needed to enable the detection of a single failing sensor, but still it remains unclear whether the failure is in the sensor or cabling.

Membership monitoring provides a basic level monitoring of signal producers [6]. Faster and more detailed validity monitoring of received signals can be based on RPDO timeout monitoring. Combining the information from membership monitoring and RPDO monitoring enables the identification of not only the error type, but also of the error location. If a signal plausibility checking is required, a CANopen design process can provide the necessary information. Additionally, most CANopen devices contain comprehensive self-monitoring functions and detected local failures are reported to the rest of the system by the emergency protocol.

## Configuration management

Parameterization is a tool to reduce the number of different product items and increase re-use by adapting standard products to various system locations. An erroneous understanding in the industry is that there are no configurable parameters in analog sensors and actuators. There are typically vendor- and device-specific mechanisms for adjusting calibration, filtering, etc. in sensors. Such services are often for the vendor's use only, limiting the usage. In actuators, the case is totally different, especially in hydraulic valves. There are e.g. plenty of slightly different main spools, various springs with different spring forces or spring force adjustments with washers, pressure compensator, load-pins, and optional valve elements for protection purposes.

Some of those parameters, which have traditionally been configured by changing the spools and springs, may currently be adjusted by changing the parameter values of the internal valve controller. Pure mechanical and hydraulic options, which cannot be changed over a CANopen network, are still identified in the device identity [12], providing a detailed checking during the network start-up phase. However, a good quality assurance is required in order to avoid assembly failures, causing mismatches between planned and realized constructions. From a safety point of view, it is essential to be able to check that correct sensors and actuators are used. Based on experience, end users are "quite innovative" and instructions can never stress enough why the control system must be able to perform the membership and configuration monitoring instead. ▷

A clear division between factory calibration and user configuration [4] is highly recommended. During the down-load process these also need to be separated, in order to prevent messing up the categories [7]. In addition, to make parameters manageable, the configuration management process supports flexible production arrangements between system integrators, subcontractors, and component vendors. Storing parameters in numeric values enables a constant production quality and the possibility to verify the assigned values after set and store.

## Design process

There is no uniform approach to the management of analog sensor and actuator interfaces. Instead, various written documents are used and each input and output must be configured manually in design-time and calibrated after the assembly, before full operation. Any component change leads to the need for a re-calibration. The major problem is the significance of human effort in each phase of the process.

Most of the listed safeguards are supported by the comprehensively standardized CANopen design process [6]. It is important to manage design information systematically in order to avoid errors. Human mistakes can be avoided by using the appropriate tools instead of human work. An appropriate tool chain enables the validation and re-use of information to/from a CANopen system project [10].

The design process can be considered as a procedure that provides consistent information for configuration management and various other monitoring functions. Not all of the required information is necessarily available in CANopen projects, which leads to interactions with other disciplines [5]. Information sharing is not possible if information content is not well defined and structured.

In addition to its extremely reliable communication services, CANopen provides further safeguards in order to decrease the residual error probability of communication and to increase the diagnostic coverage. Device profiles enable the efficient re-use of standardized basic sensing and actuation functions. Implemented in off-the-shelf devices, such functions have already been tested and certified, without additional cost or effort. Device state-machines provide protection against communication errors, causing e.g. unintentional error recovery, which violates one of the main safety design principles.

Detailed membership monitoring is a function which cannot be implemented in analog sensors and actuators and is intrinsically available in each CANopen system. Receiving PDOs by multiple devices, regardless of the need of included signal values, can be used to increase error detection performance by extending the spatial distribution. The more receiving devices, the more reliable an operation will become due to spatial coverage.

CANopen defines a comprehensive configuration management, which applies equally to all kinds of compliant devices. A harmonized principle enables an efficient and reliable system-wide configuration management. Configuration management is supported by the standardized design process, providing a systematic approach for the

management of design information, including meta information of signals and parameters, throughout the system's life cycle. A well-defined design process also maximizes the possible re-use of design information.

## Discussion

It has been concluded that determining the exact residual error probability of CANopen communication analytically is challenging, due to the structure of CAN messages. However, based on the existing information, the residual error probability is low enough for most applications [10]. When compared with old analog instrumentation, the difference is significant [11]. Based on existing analyses made by following the related standards and using real failure statistics, it may be concluded that it might not make sense to use analog sensors and actuators in safety relevant control system functions. While CANopen is not considered a safety bus, most of its basic concepts follow "inherently safe design measures" [1].

In addition to the communication, the dependability of applications is critical [11]. The main methods for improving the dependability of application programs are a managed design process and testing. As long as additional costs are not acceptable, the re-use of applications enables a more complete testing. One of the best re-use methods is to use standardized basic functions, which are defined in device profiles in CANopen. From a system point of view, a higher dependability typically results in a better availability and profitability of target systems.

When analog instrumentation and CANopen networking are compared, the latter can be achieved much simpler, while the same performance level is achieved. Analog instrumentation is more traditional, has typically less functions, and seems simple to design. One reason for its virtual simplicity is that lots of systematics have not been defined in a lot of detail. Therefore the assembly and service of analog instrumentation is error-prone and needs lots of human effort. However, defined methods must be followed in order to get the benefits of CANopen. ◀



### Authors

Heikki Saha  
TK Engineering  
[www.tke.fi](http://www.tke.fi)  
[References](#)

# World champion in tradeshows

No other country hosts as many market-leading fairs and exhibitions: In 2015, 161 tradeshows will take place in Germany. For CAN interested parties, the season starts with the Embedded World in Nuremberg.

In Germany, more people visit fairs than watch prime league (Bundesliga) soccer games. They walk through badly air-conditioned halls, and visit sometimes not so well designed booths. They talk to more or less qualified stand personal including always smiling hostesses. Why do so many Germans bore themselves on fairgrounds?

We need to look back into history: In the year 1165, Leipzig, the capital of Saxony, got the right to hold a weekly market. It is regarded as the “mother of all fairs”. Many urban and regional markets followed. During the industrial revolution dedicated exhibitions popped up. In 1897, the [IAA](#) (International Automobile Exhibition) opened its doors for the first time. Today, many of the market-leading exhibitions are located in Germany. The [Hanover Fair](#) with its spin-offs the [Bauma](#) (construction and mining machines) in Munich, and the [Innotrans](#) (rail vehicles), are known worldwide.

About 30 percent of the German fairground visitors are from abroad. One half of the 168 000 exhibitors are not from Germany according to the AUMA association of fair organizers. Germany also exports trade fairs, e.g. the [Bau-ma Shanghai](#). About 2000 employees from the 14000 German fair staff work outside of Germany.

Fairs are an ideal place to meet suppliers, to get an overview on products and technologies, and to talk to other experts including competitors. This is one of the German strengths: Discussing topics, which are pre-competitive. Fairgrounds are an ideal location for such discussions, which lead often to joint activities such as establishing interest groups. The very first idea of the CiA association was also born on a fairground. In 1991 at the Systems in Munich, several companies discussed the need of standardized CAN physical layers and CAN-based higher-layer protocols. A few months later, they established the non-profit CAN in Automation (CiA) users' and manufacturers' group.

For CAN interested parties, several industry-specific events are important. This includes the [Embedded World](#) (micro-controller and board-level products) and the [SPC IPC Drives](#) (industrial automation devices). Both are located in Nuremberg. Of course, there are also some very specific tradeshows such as the [Sensor+Test](#) in Nuremberg, the [Interlift](#) (sub-systems and devices for elevators) in Augsburg, and the [SMM](#) (maritime electronics) in Hamburg. Bi-annually, the [Electronica](#) takes place in Munich, where all the major chipmakers exhibit their CAN products. And there are many more exhibitions and fairs, where CAN is a topic – sometimes hidden, so-to-say embedded. Typical examples include the [Husum Wind](#) and the [Automatica](#) in Munich.

Holger Zeltwanger





CAN-PCIe/402

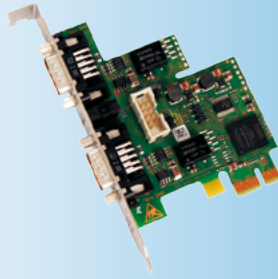

**CAN-PCIe/402**

- up to 4 high performance PCI Express CAN interfaces
- DMA busmaster
- Powered by esd Advanced CAN Core (esd-ACC)
- MSI (Message Signaled Interrupt) support
- Electrically isolated
- Provides high resolution hardware timestamp

CAN-USB/400



**CAN-USB/400**

- 2 high performance CAN-USB interfaces
- Powered by esd Advanced CAN Core (esd-ACC)
- USB 2.0 with high speed data rates of 480 Mbit/s
- Electrically isolated
- Provides high resolution hardware timestamp
- Error injection for advanced diagnostic
- IRIB B timecode as option

CAN-PCI/400

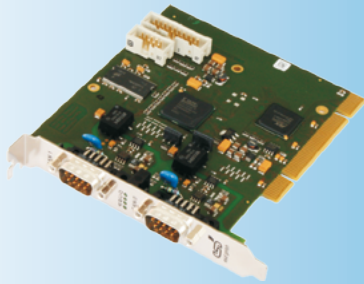

**CAN-PCI/400**

- up to 4 high performance CAN interfaces
- Powered by esd Advanced CAN Core (esd-ACC)
- Electrically isolated
- Provides high resolution hardware timestamp
- Error injection for advanced diagnostic

Ethernet



**CAN-PCI104/200**

- PCI104-CAN interface
- One or two CAN interfaces for PCI104 bus

**EtherCAN/2**

- 10/100 BaseT ETHERNET-CAN Gateway
- Electrically isolated
- Configuration and Diagnostics by webbrowser

CAN-USB/2



**CAN-USB/2**

- CAN-USB interface
- Intelligent CAN interface with ARM 7
- USB 2.0 with high speed data rates of 480 Mbit/s
- Electrically isolated
- Provides high resolution hardware timestamp

**Gateways**

- EtherCAT-CAN
- PROFINET-CANopen
- PROFIBUS-CANopen
- PROFIBUS-DeviceNet
- EtherNet/IP-CAN

**Operating Systems**

esd supports the real-time multitasking operating systems VxWorks, QNX, RTX, RTOS-32 and others as well as Linux and Windows 32/64Bit systems

Gateways



**CAN Tools**

- CANreal: Display and recording of CAN message frames
- CANplot: Display of online/offline CAN data
- CANrepro: Replay of pre-recorded CAN message frames
- CANscript: Python scripting tool to handle CAN messages
- COBview: Analysis and diagnostics of CANopen nodes

*The tools are free of charge on the driver CD or can be downloaded at [www.esd.eu](http://www.esd.eu)*





## Solutions for Open Networks from one Source

Open CAN-based protocols are the basis of networking in commercial vehicles, avionics and industrial control technology. Vector supports you in all development phases of these systems:

- > Systematic network design with CANoe, ProCANopen and CANeds
- > Successful implementation with source code for J1939 and more
- > Efficient configuration, test and extensive analysis with ProCANopen, CANoe and CANalyzer

Multifaceted trainings and individual consulting complete our extensive offerings.

**Thanks to the close interlocking of the Vector tools and the competent support, you will increase the efficiency of your entire development process from design to testing.**

- ▶ **Further information, application notes and demos:**  
[www.vector.com/opennetworks](http://www.vector.com/opennetworks)